

09 (2x)

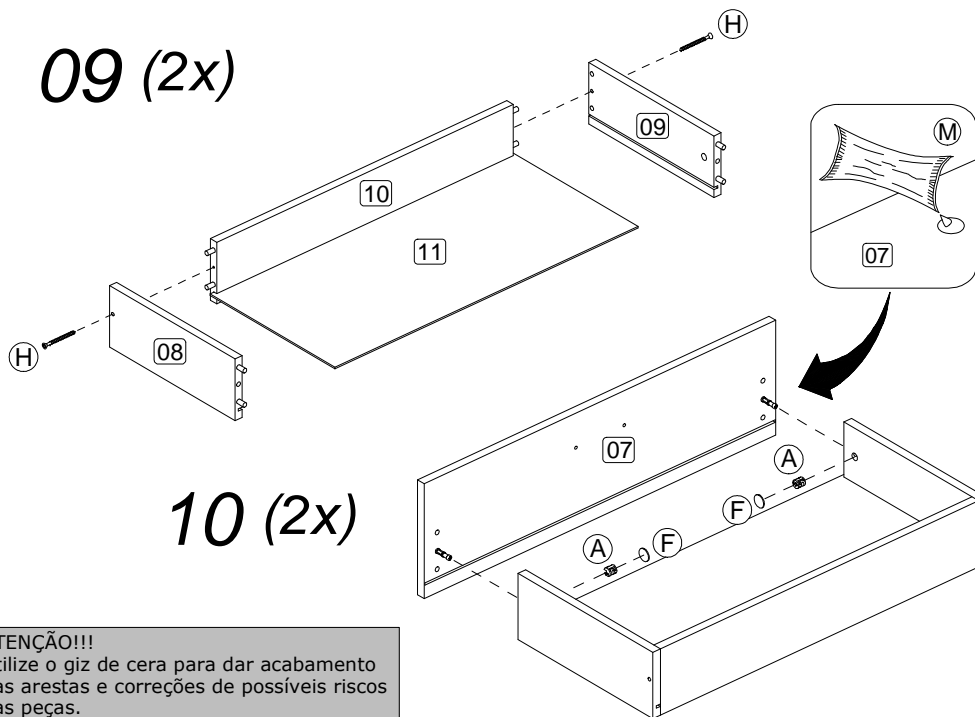

10 (2x)

ATENÇÃO!!!
Utilize o giz de cera para dar acabamento nas arestas e correções de possíveis riscos nas peças.

ATENCIÓN!!!
Utilice el gis para los bordes y correcciones de posibles errores o daños en las piezas.

ATTENTION!!!
Use the crayons to finish edges and to fix possible damaged pieces.

11 (2x)

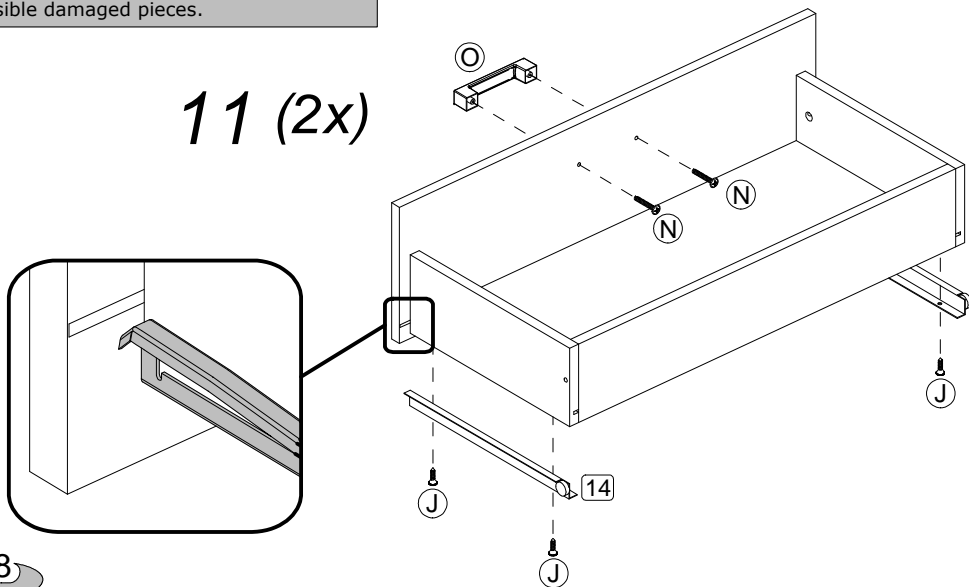

8

INSTRUÇÕES DE MONTAGEM
INSTRUCTIVO DE ARMADO
ASSEMBLY INSTRUCTIONS



RSC 470 - km 203,3 BENTO GONÇALVES - RS - BRASIL
FONE: 54-3458.1300
sac@politorno.com.br
www.politorno.com.br

Estante Livramento Porta Vidro
Biblioteca Livramento Puerta Vidrio
Bookcase with Glass Door

Modelo
Modelo
Modelo

2354

Caso você precise da indicação de um montador, consulte o site www.politorno.com.br. Temos profissionais capacitados para indicar nas principais cidades do Brasil.

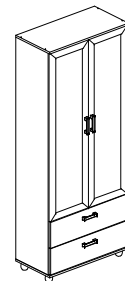

KIT FERRAGEM
KIT HERRAJE
HARDWARE KIT

A		12
B		12
C	08x30	32
D	10x10	50
E		12
F		08
H	4,5x45	12
I	5,0x30	04
J	3,0x14	16
K	8mm	04
L	Giz / Gis / Crayons	03
M		01
N	3,5x25	08
O		04
P	3,5x14	24
Q		06
R		06

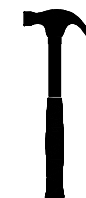

Rev 01

ANTES DE INICIAR A MONTAGEM, IDENTIFIQUE TODAS AS PEÇAS E ACESSÓRIOS.
 ANTES DE EMPEZAR EL ARMADO, IDENTIFIQUE TODAS LAS PIEZAS Y ACCESORIOS.
 BEFORE STARTING THE ASSEMBLY, IDENTIFY ALL PARTS AND ACCESSORIES.

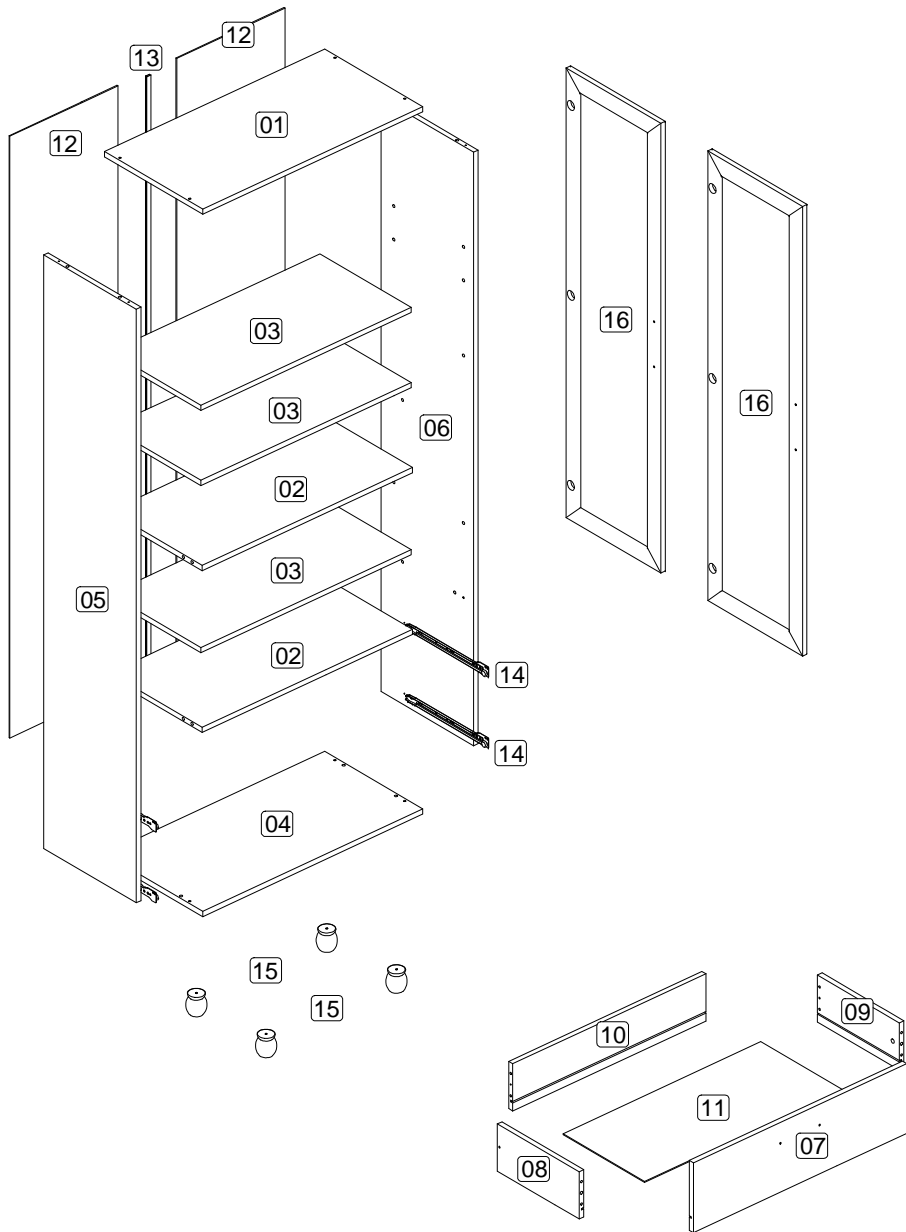

07

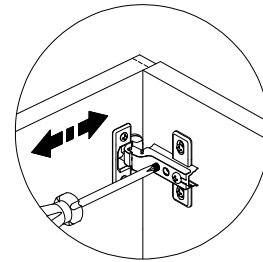

Regulagem Horizontal
 Ajuste Horizontal
 Horizontal Adjustment

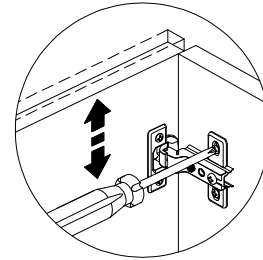

Regulagem Vertical
 Ajuste Vertical
 Vertical Adjustment

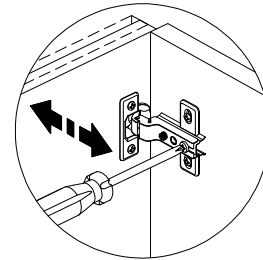

Regulagem Profundidade
 Ajuste Profundidad
 Depth Adjustment

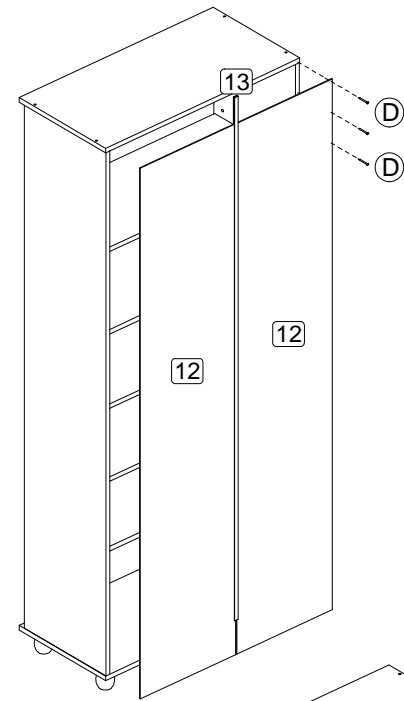

08

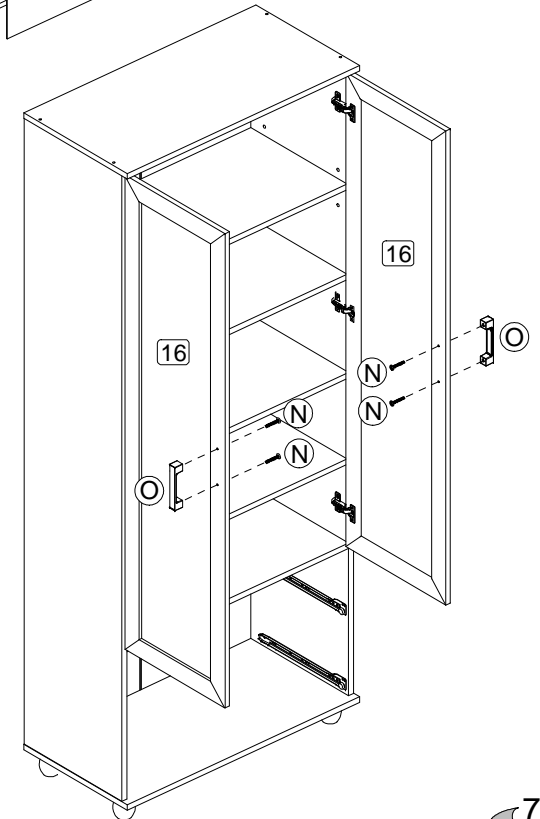

06

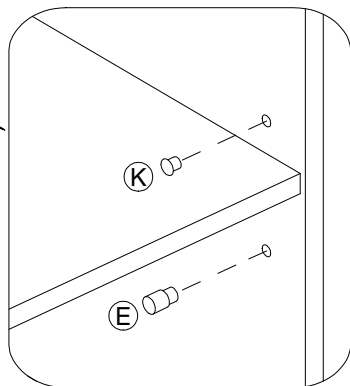
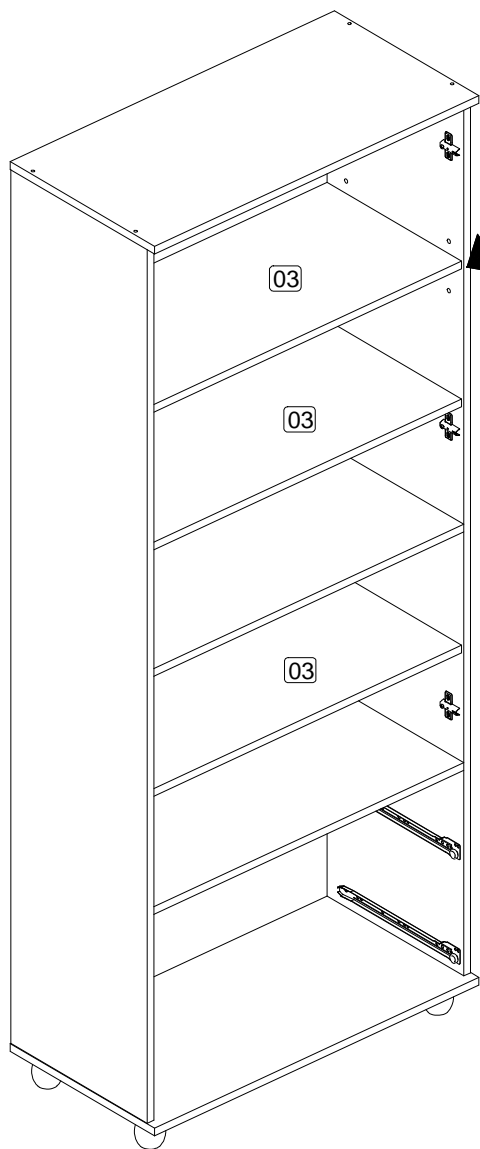

ou/ o / or

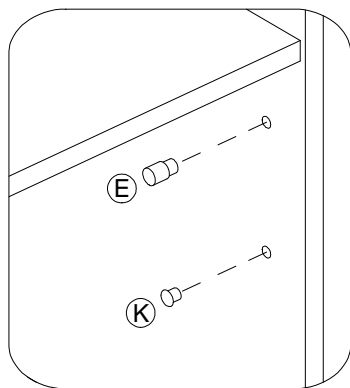

01

ETAPA DE PREPARAÇÃO DAS PEÇAS.
FASE DE PREPARACIÓN DE LAS PIEZAS.
STAGE OF PREPARATION OF THE PIECES.

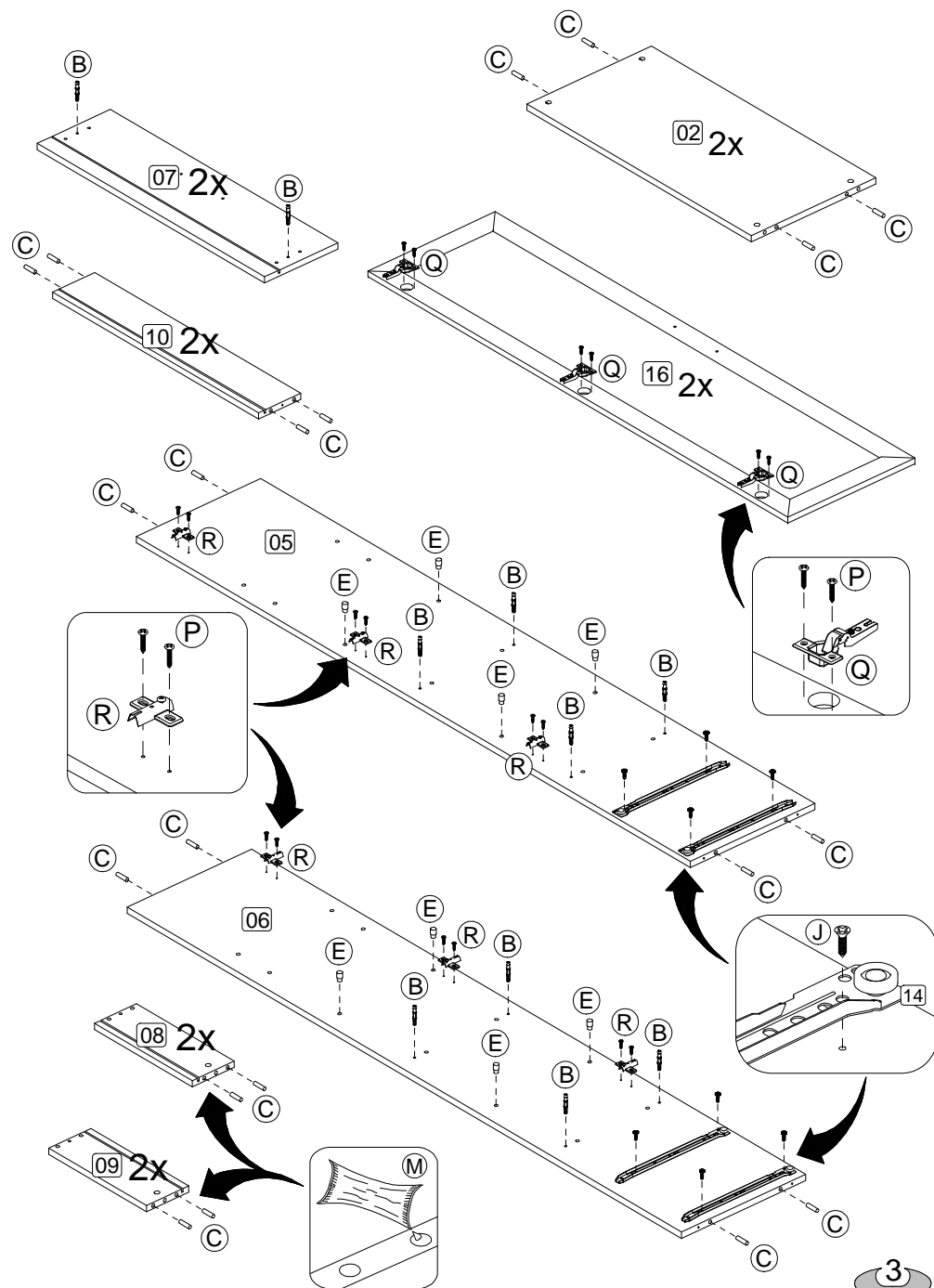

02

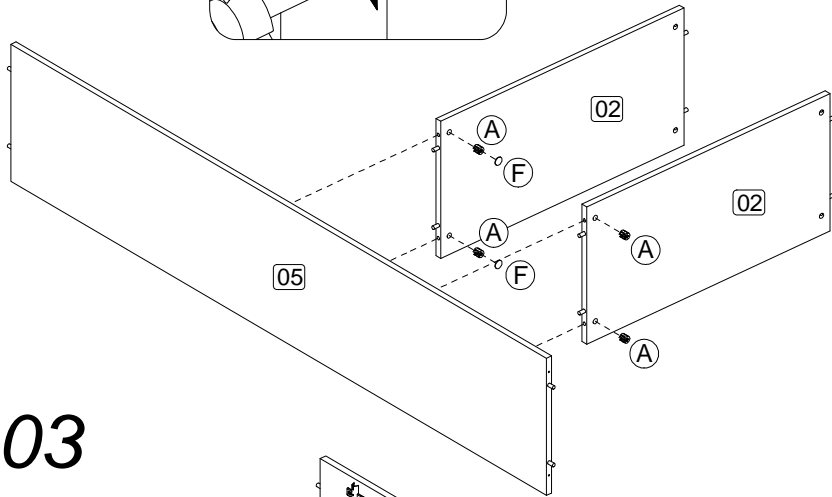
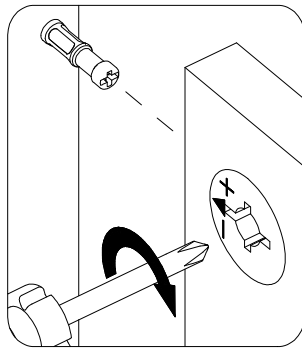

03

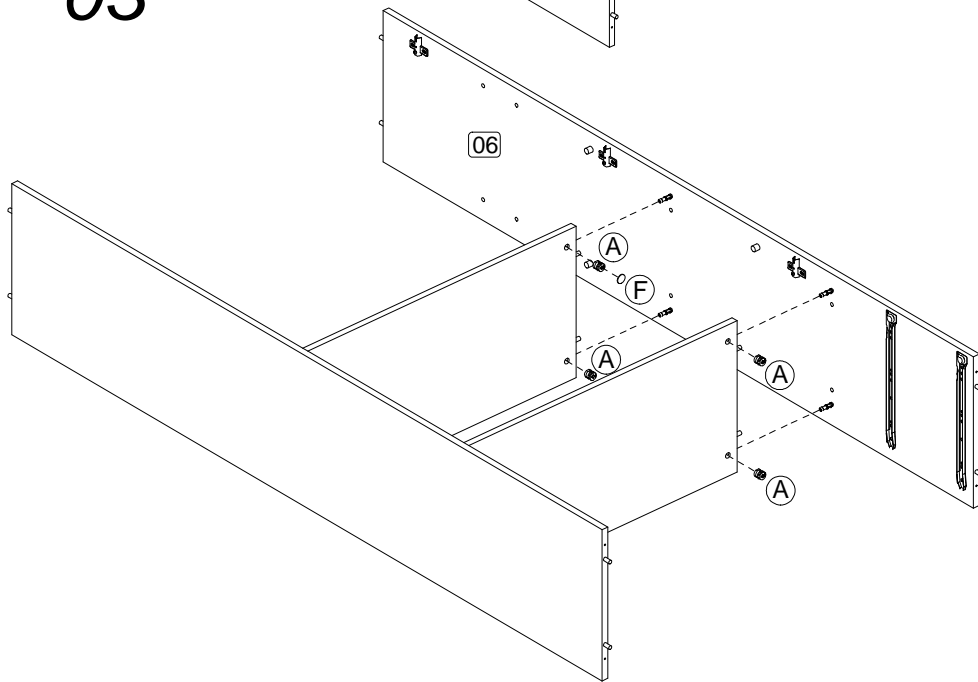

04

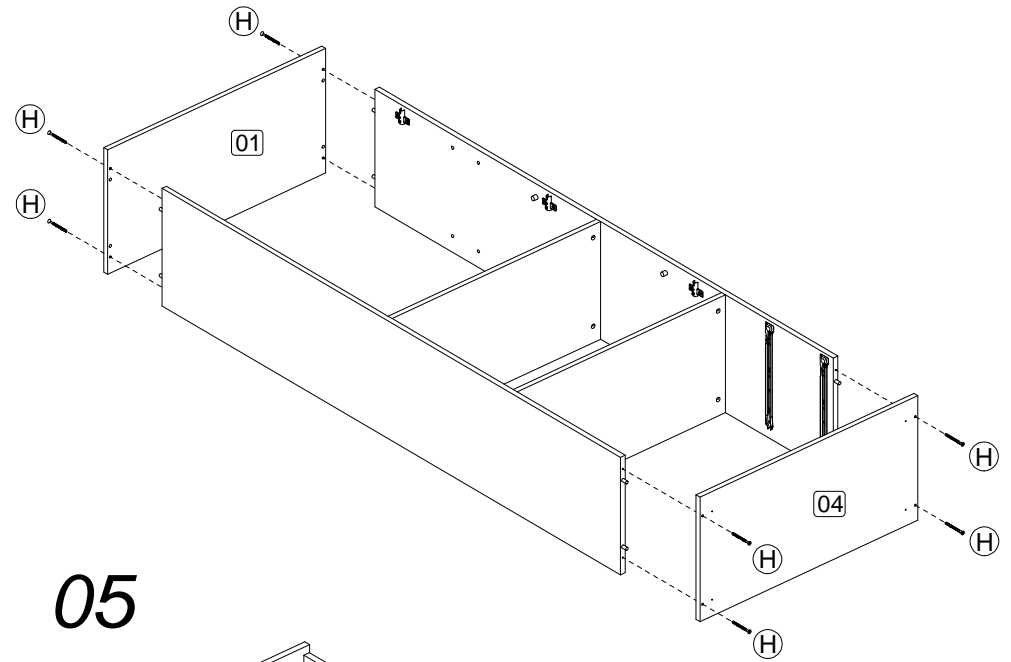

05

