

# ASSEMBLY INSTRUCTIONS MANUAL DE MONTAGEM / INSTRUCCIONES DE ARMADO

TOP 31 1/2"  
TAMPO 800MM  
TAMPA 800MM

Reference  
Referência  
Referencia **240541** | Revise  
| Revisão  
| Revisión **00**

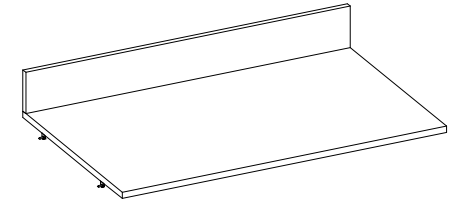

**YOU WILL NEED  
VOCÊ VAI PRECISAR DE / USTED NECESITARÁ**

Tools not supplied  
Ferramentas não fornecidas / Herramientas no incluidas

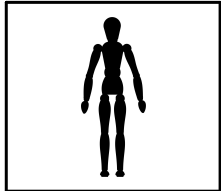

1 Person  
1 Pessoa  
1 Persona

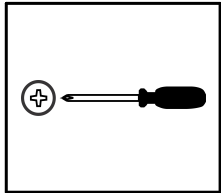

Screwdriver Phillips  
Chave Phillips  
Destornillador cruz

**PARTS IDENTIFICATION  
IDENTIFICAÇÃO DAS PEÇAS / IDENTIFICACIÓN DE LAS PIEZAS**

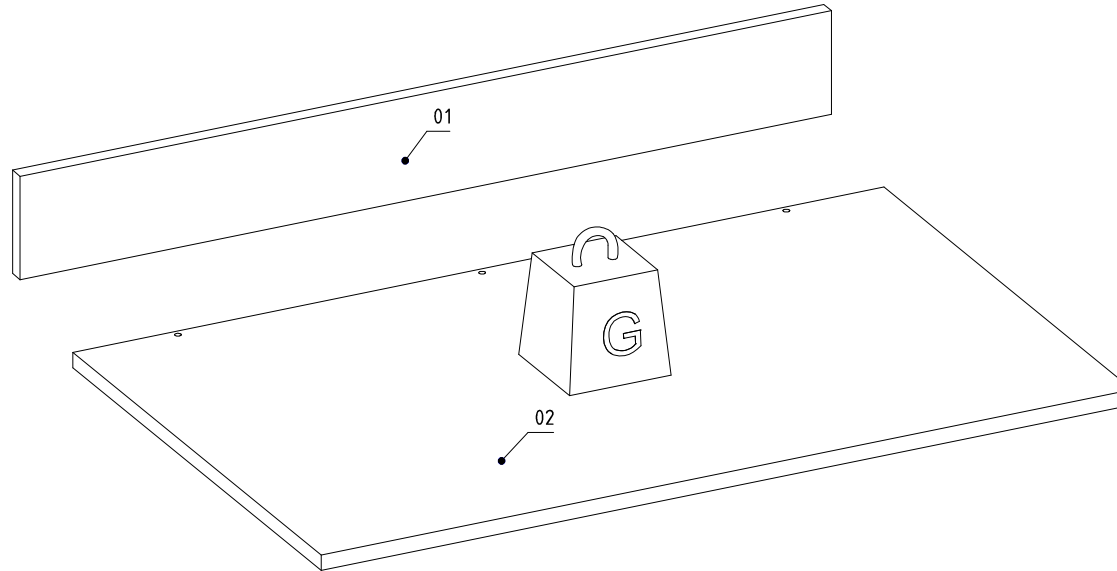

Nº	Measures_Inches	Medidas_cm	Qty./Qtd.
01	31 1/2 x 3 7/8 x 5/8	80.0 x 10.0 x 1.5	1
02	31 1/2 x 19 1/4 x 5/8	80.0 x 49.0 x 1.5	1



MAXIMUM RECOMMENDED WEIGHT  
BEING THIS EVENLY DISTRIBUTED.

PESO MÁXIMO RECOMENDADO SENDO  
ESTE DISTRIBUÍDO UNIFORMEMENTE.

PESO MÁXIMO RECOMENDADO SIENDO  
ESTE UNIFORMEMENTE DISTRIBUIDO.

	LB	KG
G	33	15

## IDENTIFICATION OF ACCESSORIES IDENTIFICAÇÃO DOS ACESSÓRIOS/ IDENTIFICACIÓN DE ACCESORIOS



The separation of the accessories before you start the assembly will facilitate the same. In case of doubt on the size of the screws and bolts, use the ruler to bottom of page.  
 A separação dos acessórios antes de iniciar a montagem facilitará a mesma. Em caso de dúvida no tamanho dos parafusos e cavilhas, utilize a régua ao final da página.  
 La separación de los accesorios antes de comenzar el armado facilitará el mismo. En caso de duda sobre el tamaño de los tornillos y taquetes, utilice la regla al pie de página.

D		Flat head screw Parafuso chato / Tornillo de cabeza plana	4,0x40 mm	3
S		Pan head screw Parafuso panela / Tornillo de pan	3,5x14 mm	8
Y18		Zamac bracket Cantoneira zamac/ Suporte de zamac	13x13 mm	4

## ASSEMBLY MONTAGEM / ARMADO

01

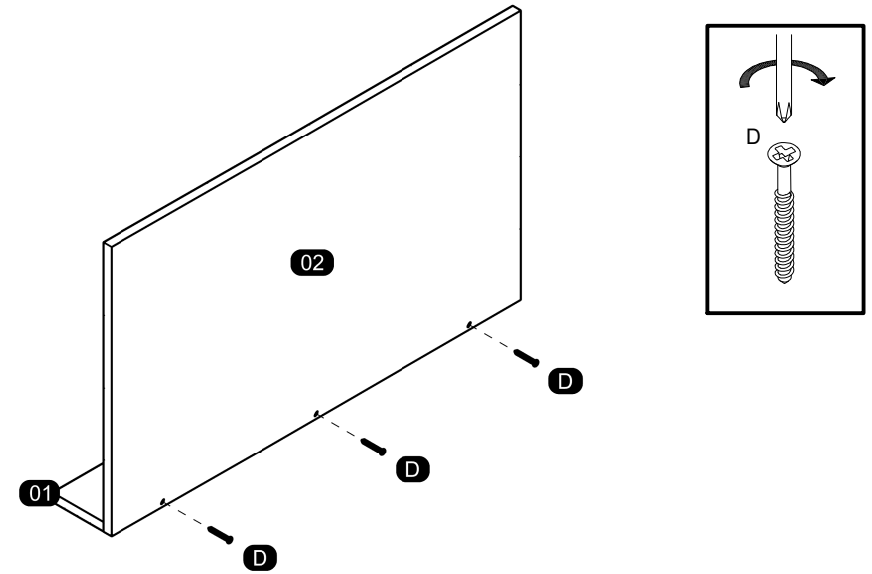

02

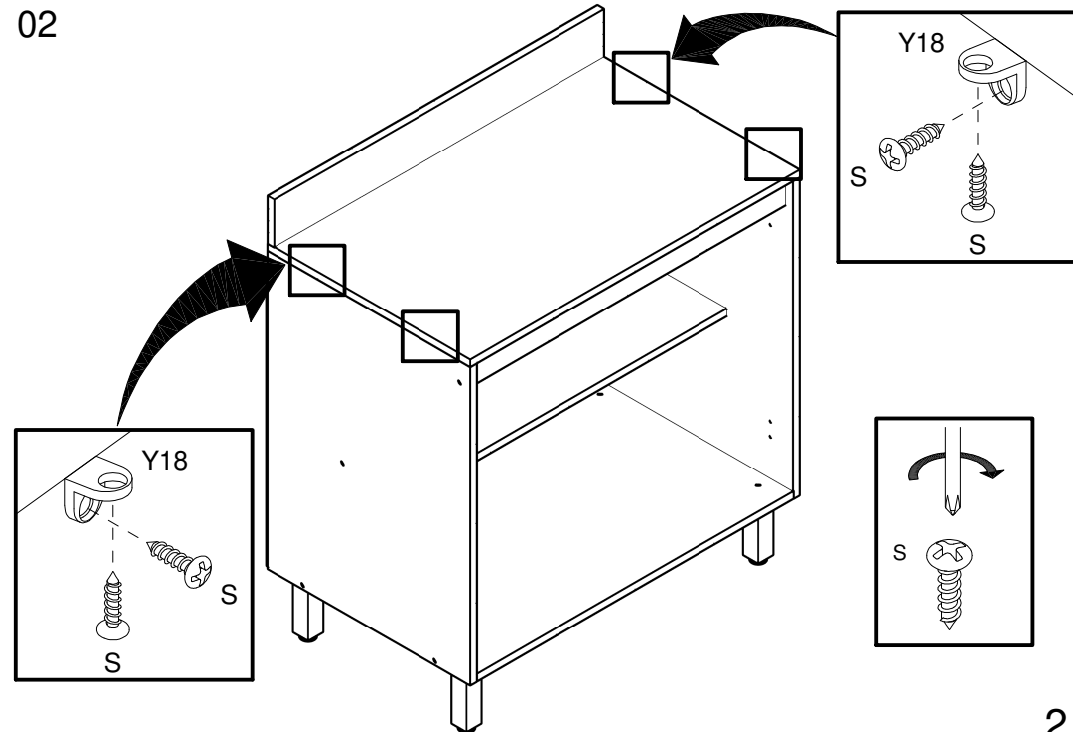

# ASSEMBLY INSTRUCTIONS MANUAL DE MONTAGEM / INSTRUCCIONES DE ARMADO

2 DOORS BASE CABINET  
BALCAO 2P  
BALCÓN 2 PUERTAS

Reference  
Referência  
Referencia **240601** | Revise  
| Revisão  
| Revisión **00**

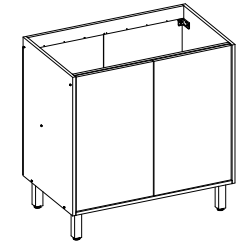

**YOU WILL NEED  
VOCÊ VAI PRECISAR DE / USTED NECESITARÁ**

Tools not supplied  
Ferramentas não fornecidas / Herramientas no incluidas

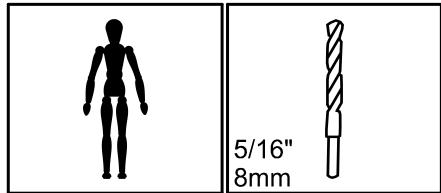

1 Person  
1 Pessoa  
1 Persona

Drill bit  
Broca  
Taladro

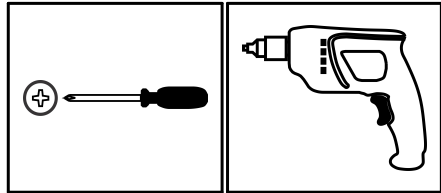

Screwdriver Phillips  
Chave Phillips  
Destornillador cruz

Drill machine  
Furadeira  
Taladro

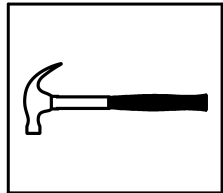

Hammer  
Martelo  
Martillo

**MAXIMUM RECOMMENDED WEIGHT  
BEING THIS EVENLY DISTRIBUTED.**  
**PESO MÁXIMO RECOMENDADO SENDO  
ESTE DISTRIBUÍDO UNIFORMEMENTE.**  
**PESO MÁXIMO RECOMENDADO SIENDO  
ESTE UNIFORMEMENTE DISTRIBUIDO.**

—	LB	KG
F	22	10

**PARTS IDENTIFICATION  
IDENTIFICAÇÃO DAS PEÇAS / IDENTIFICACIÓN DE LAS PIEZAS**

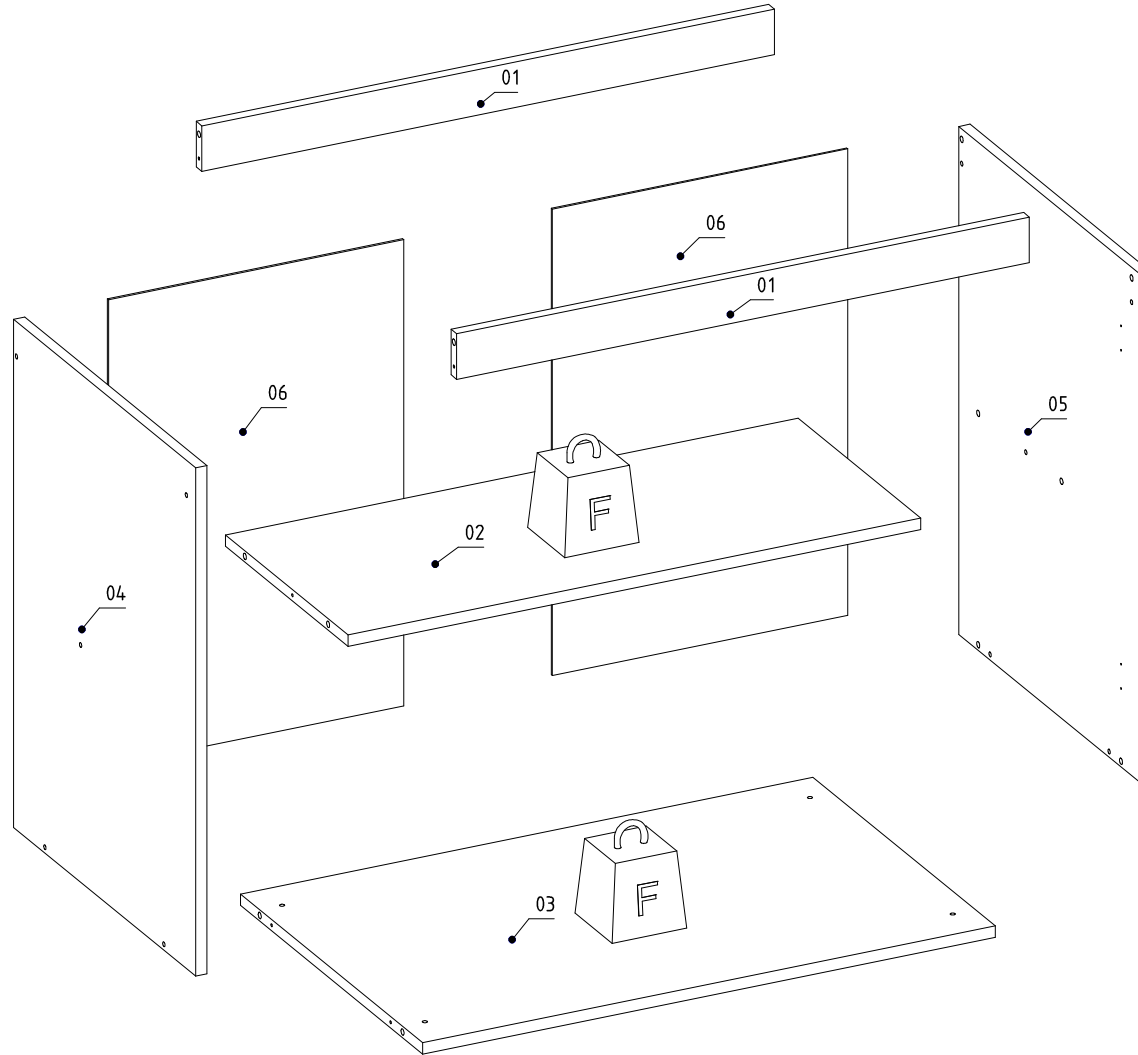

Nº	Measures_Inches	Medidas_cm	Qty./Qtd.
01	30 3/8 x 2 3/8 x 5/8	77.0 x 6.0 x 1.5	2
02	30 3/8 x 13 x 5/8	77.0 x 33.0 x 1.5	1
03	30 3/8 x 19 1/4 x 5/8	77.0 x 49.0 x 1.5	1
04	26 3/8 x 19 1/4 x 5/8	67.0 x 49.0 x 1.5	1
05	26 3/8 x 19 1/4 x 5/8	67.0 x 49.0 x 1.5	1
06	24 1/4 x 15 5/8 x 1/8	61.5 x 39.7 x 0.3	2

## IDENTIFICATION OF ACCESSORIES IDENTIFICAÇÃO DOS ACESSÓRIOS/ IDENTIFICACIÓN DE ACCESORIOS



The separation of the accessories before you start the assembly will facilitate the same. In case of doubt on the size of the screws and bolts, use the ruler to bottom of page.  
 A separação dos acessórios antes de iniciar a montagem facilitará a mesma. Em caso de dúvida no tamanho dos parafusos e cavilhas, utilize a régua ao final da página.  
 La separación de los accesorios antes de comenzar el armado facilitará el mismo. En caso de duda sobre el tamaño de los tornillos y taquetes, utilice la regla al pie de página.

A		Flanged head screw Parafuso flangeado / Tornillo de cabeza flangeada	5,0x60 mm	2
A23		Foot Pé Quadrado FP / Pie	140 mm	4
B3		Bushing Bucha expansiva / Tapón	8x50 mm	2
C		Flanged head screw Parafuso flangeado / Tornillo de cabeza flangeada	4,5x45 mm	4
C1		Metal claw Garra de metal / Garra metal	-	1
D5		Hinge shim Calço dobradiça / Bisagra de calce	-	4
D6		Metal hinge super hight Dobradiça super alta / Bisagra alta	26mm	4
E		Wooden dowel Cavilha / Taquete	8x30 mm	12
N		Nail Prego / Clavo	10x10	31
N5		Support "L" Suporte "L" / Soporte "L"	-	2
O		Flat head screw Parafuso chato / Tornillo de cabeza plana	4,5x45 mm	10
S		Pan head screw Parafuso panela / Tornillo de pan	3,5x14 mm	20



## PRE-ASSEMBLE PRÉ-MONTAGEM / PRE ARMADO

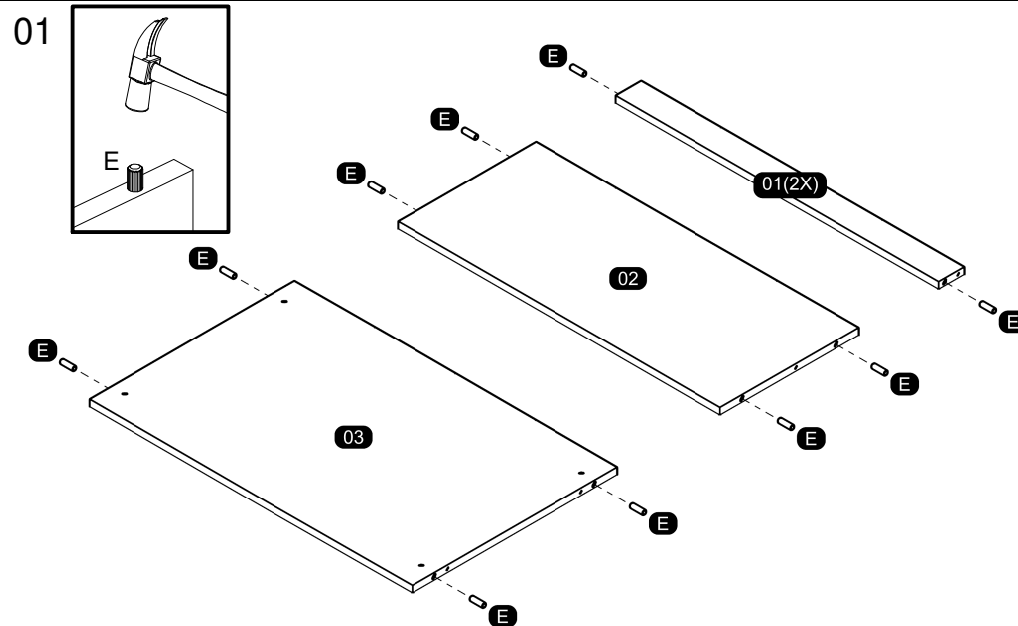

## ASSEMBLY MONTAGEM / ARMADO

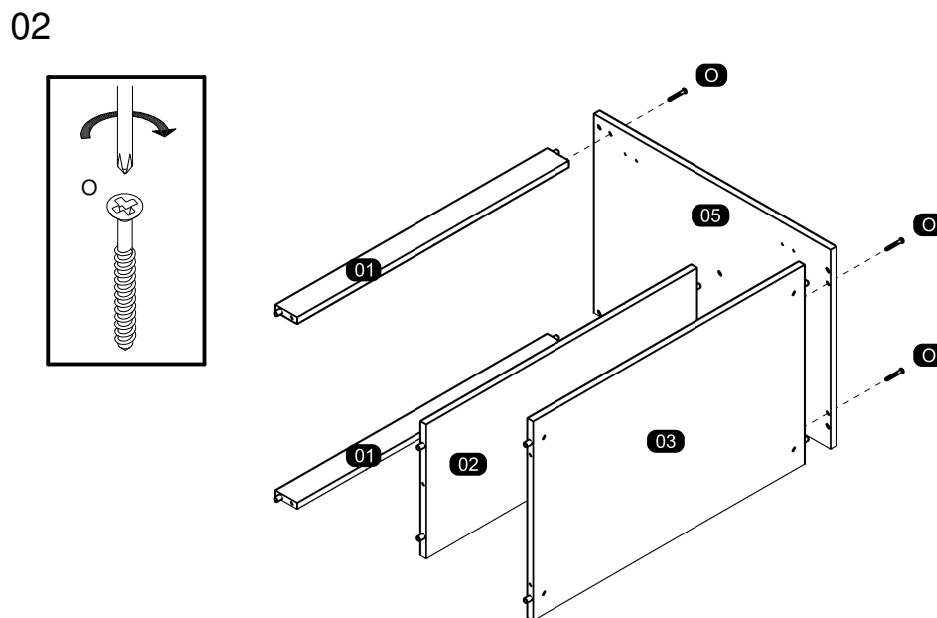

03

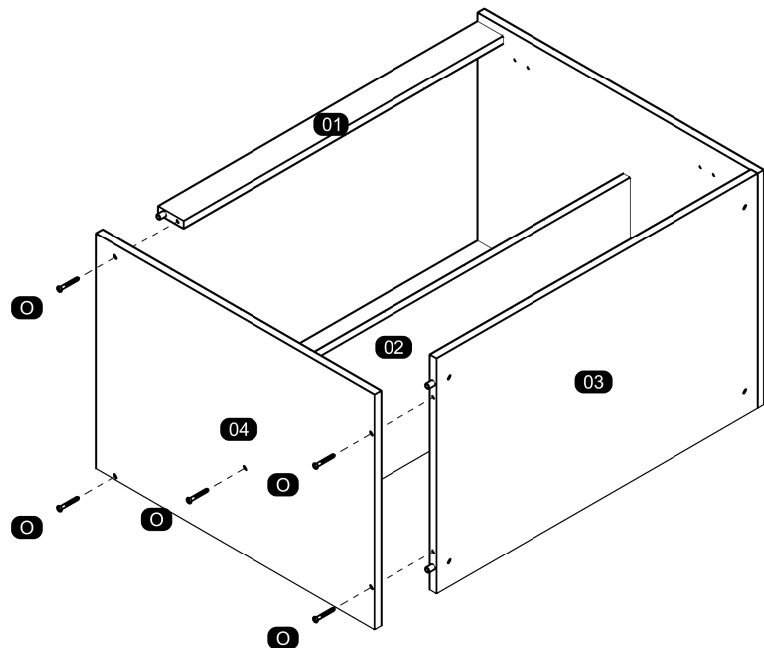

05

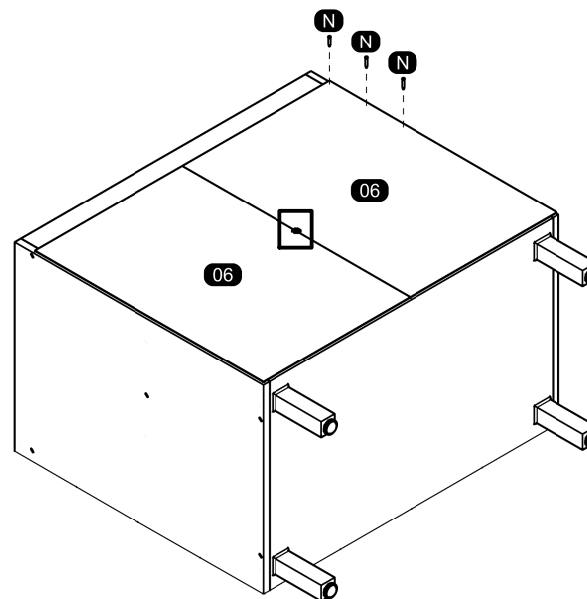
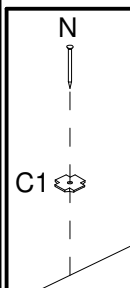

Furniture back  
 Parte traseira do móvel  
 Trasero del mueble

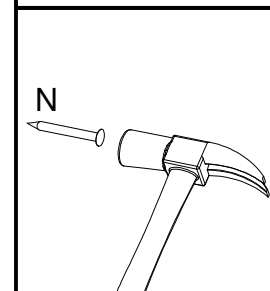
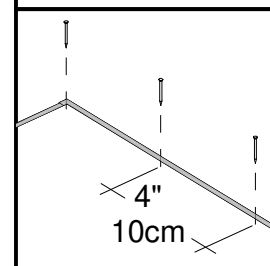

04

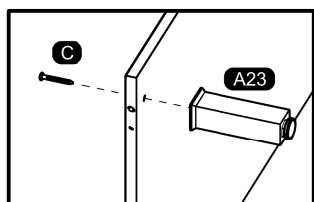
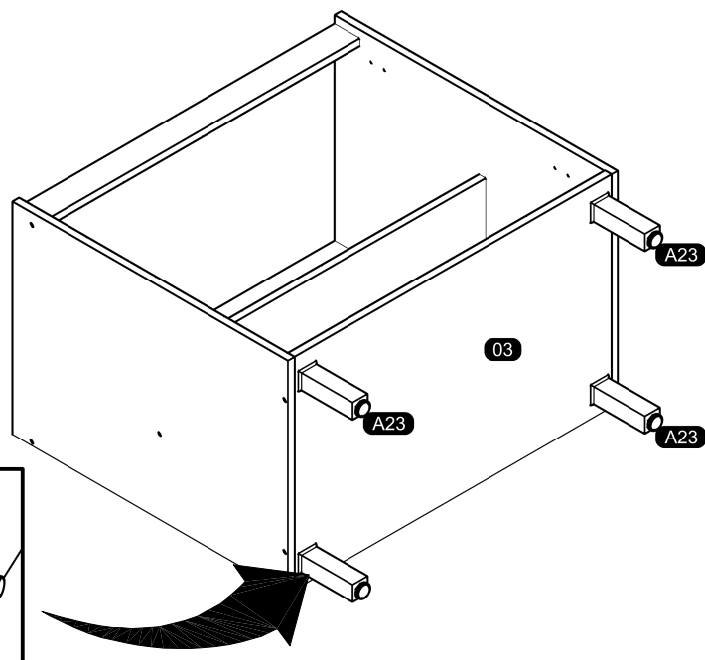

06

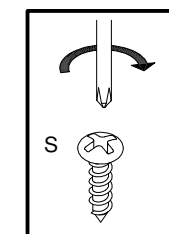
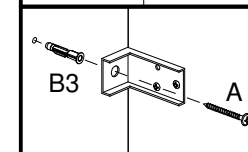
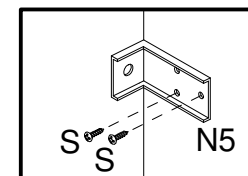
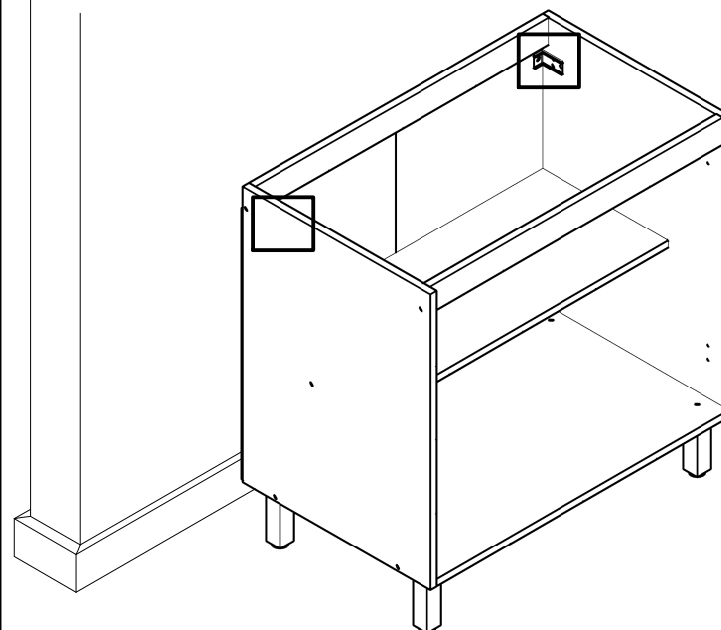

# ASSEMBLY INSTRUCTIONS MANUAL DE MONTAGEM / INSTRUCCIONES DE ARMADO

KOYA DOORS CABINET 2D  
PORTAS KOYA BALCÃO 2P  
PUERTAS KOYA GABINETE 2P

Reference  
Referência  
Referencia

240679

| Revise  
| Revisão  
| Revisión

00



**YOU WILL NEED**  
**VOCÊ VAI PRECISAR DE / USTED NECESITARÁ**

**PARTS IDENTIFICATION**  
**IDENTIFICAÇÃO DAS PEÇAS / IDENTIFICACIÓN DE LAS PIEZAS**

Tools not supplied  
Ferramentas não fornecidas / Herramientas no incluidas

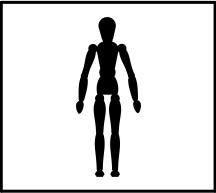

1 Person  
1 Pessoa  
1 Persona

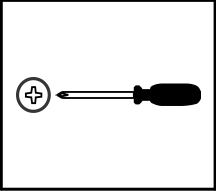

Screwdriver Phillips  
Chave Phillips  
Destornillador cruz

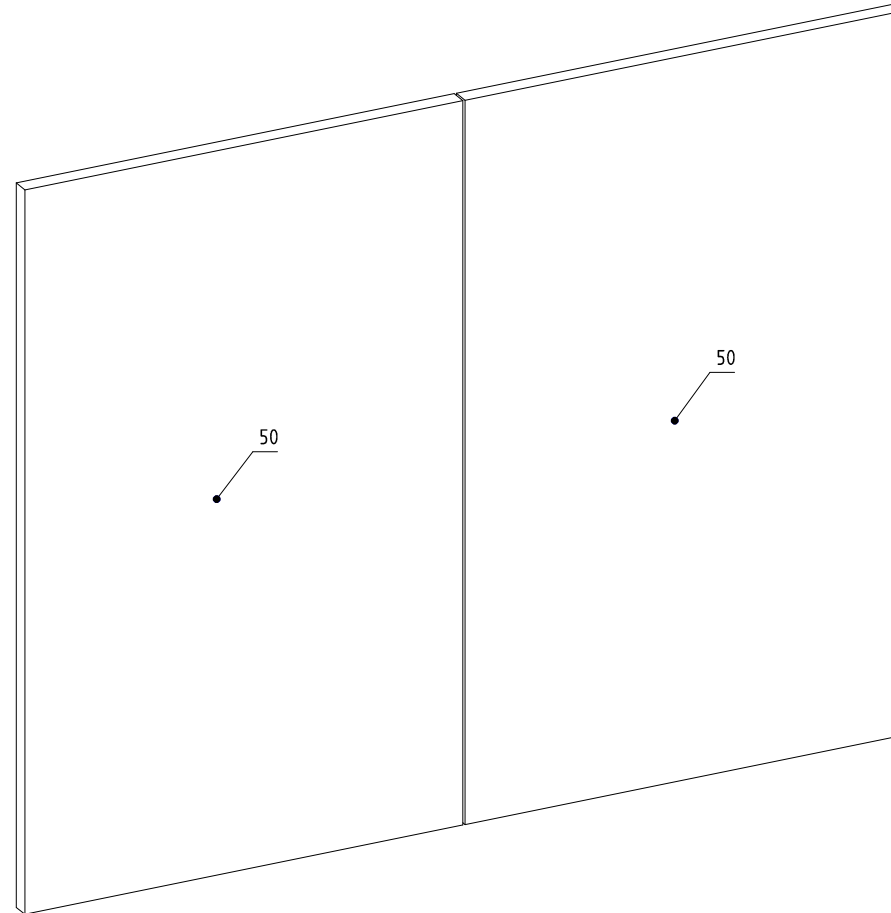

Nº	Measures_Inches	Medidas_cm	Qty./Qtd.
50	24 3/8 x 15 x 5/8	61.8 x 38.1 x 1.5	2



MAXIMUM RECOMMENDED WEIGHT  
BEING THIS EVENLY DISTRIBUTED.

PESO MÁXIMO RECOMENDADO SENDO  
ESTE DISTRIBUÍDO UNIFORMEMENTE.

PESO MÁXIMO RECOMENDADO SIENDO  
ESTE UNIFORMEMENTE DISTRIBUIDO.

—	LB	KG
---	----	----

## IDENTIFICATION OF ACCESSORIES IDENTIFICAÇÃO DOS ACESSÓRIOS/ IDENTIFICACIÓN DE ACCESORIOS



The separation of the accessories before you start the assembly will facilitate the same. In case of doubt on the size of the screws and bolts, use the ruler at the bottom of the page.  
 A separação dos acessórios antes de iniciar a montagem facilitará a mesma. Em caso de dúvida no tamanho dos parafusos e cavilhas, utilize a régua ao final da página.  
 La separación de los accesorios antes de comenzar el armado facilitará el mismo. En caso de duda sobre el tamaño de los tornillos y taquetes, utilice la regla al pie de página.

K23		Handle Puxador Gola 15mm / Tirador	381 mm	2
o5		Flanged head screw Parafuso flangeado / Tornillo de cabeza flangeada	3,5x14 mm	6



## ASSEMBLY MONTAGEM / ARMADO

02

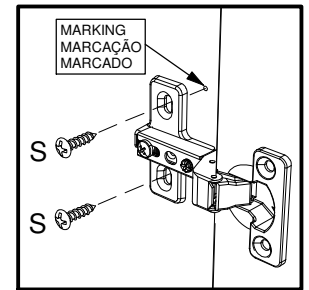
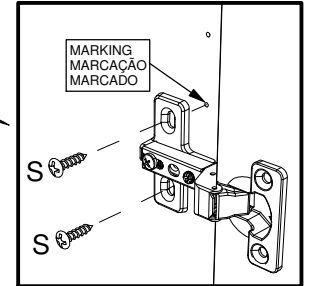
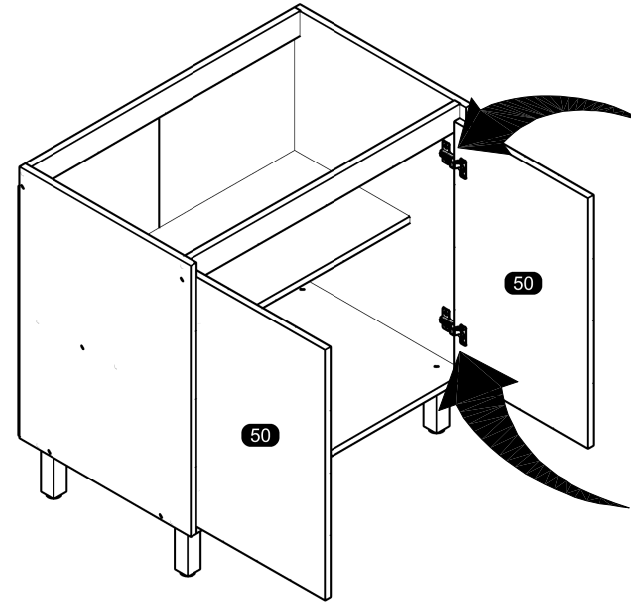

## PRE-ASSEMBLY PRÉ-MONTAGEM / PRE ARMADO

01

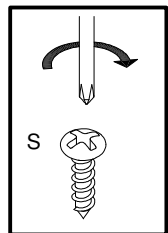
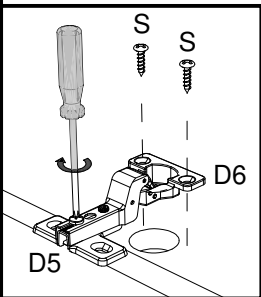
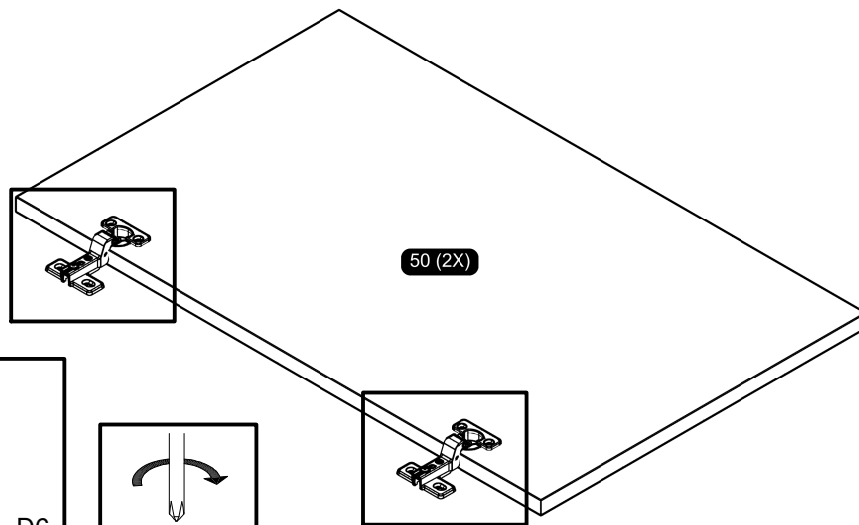

03

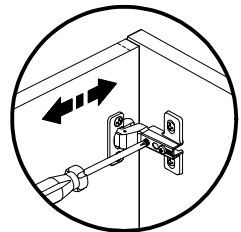
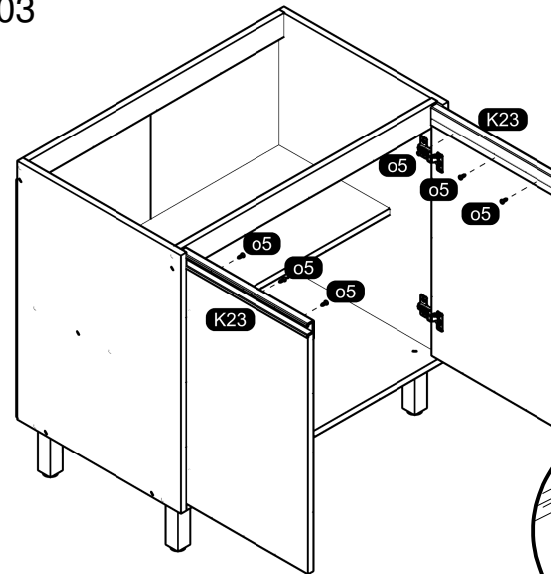

Horizontal Adjustment  
Regulagem Horizontal  
Ajuste Horizontal

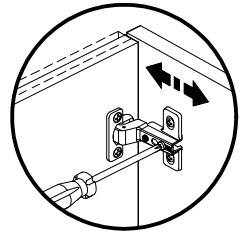

Depth Adjustment  
Regulagem Profundidade  
Ajuste Profundidad

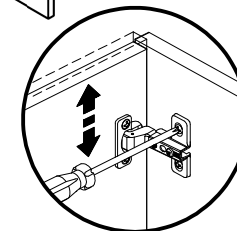

Vertical Adjustment  
Regulagem Vertical  
Ajuste Vertical