

ASSEMBLY INSTRUCTIONS MANUAL DE MONTAGEM / INSTRUCCIONES DE ARMADO

Osaka drawer cabinet - 2 drawers
Gaveteiro Osaka - 2 gavetas
Cajonera Osaka - 2 cajones

Reference | Revisão
Referência | Revisão
Referencia | Revisión

190639

01

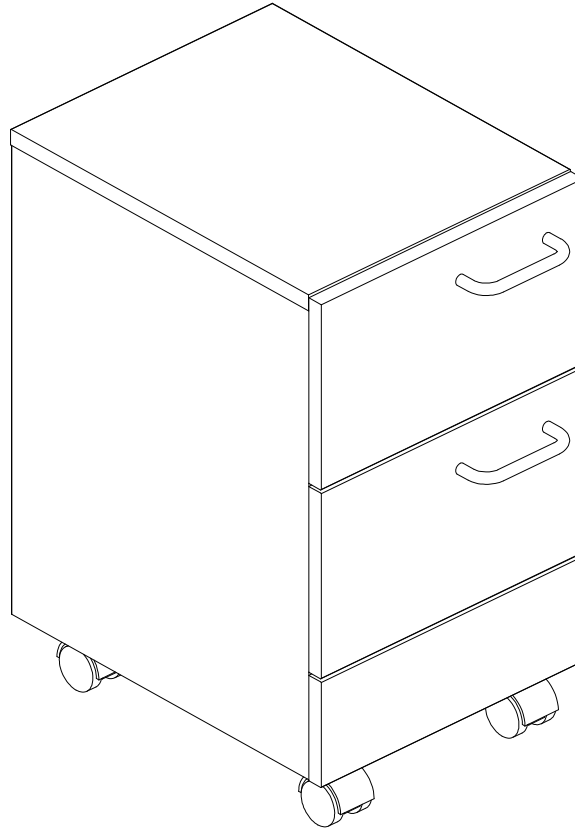

YOU WILL NEED / VOCÊ VAI PRECISAR DE / USTED NECESITARÁ

Tools not supplied / Ferramentas não fornecidas / Herramientas no incluidas

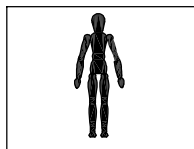

1 Person
1 Pessoa
1 Persona

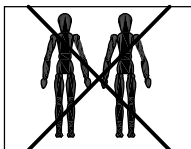

2 People
2 Pessoas
2 Personas

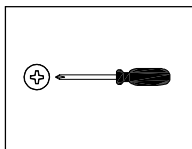

Screwdriver Phillips
Chave Phillips
Destornillador cruz

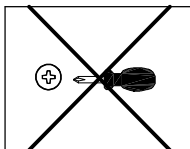

Small screwdriver Phillips
Chave Phillips Menor
Destornillador cruz menor

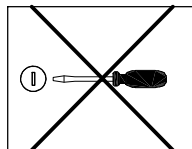

Screwdriver slotted
Chave fenda
Destornillador plano

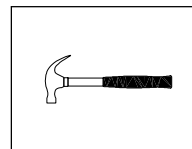

Hammer
Martelo
Martillo

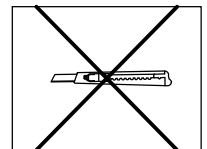

Stilet
Estilete
Estilete

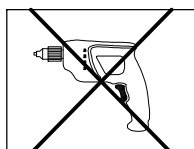

Drill machine
Furadeira
Taladro

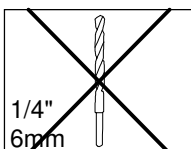

Drill bit
Broca
Taladro

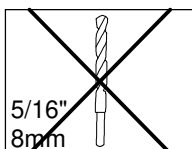

Drill bit
Broca
Taladro

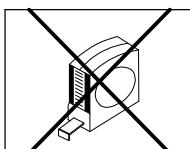

Measuring tape
Trena
Cinta de medición

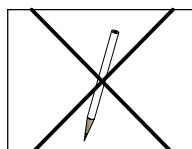

Pencil
Lápis
Lápiz

NOTES: The separation of the accessories before you start the assembly will facilitate the same. In case of doubt on the size of the screws and bolts, use the ruler to bottom of page 3.

NOTAS: A separação dos acessórios antes de iniciar a montagem facilitará a mesma. Em caso de dúvida no tamanho dos parafusos e cavilhas, utilize a régua ao final da página 3.

NOTAS: La separación de los accesorios antes de comenzar el armado facilitará el mismo. En caso de duda sobre el tamaño de los tornillos y taquetes, utilice la regla al pie de página 3.

MAXIMUM RECOMMENDED WEIGHT
BEING THIS EVENLY DISTRIBUTED

PESO MÁXIMO RECOMENDADO SENDO
ESTE DISTRIBUÍDO UNIFORMEMENTE

PESO MÁXIMO RECOMENDADO SIENDO
ESTE UNIFORMEMENTE DISTRIBUIDO

	LB	KG
A	22	10
B	6,6	3

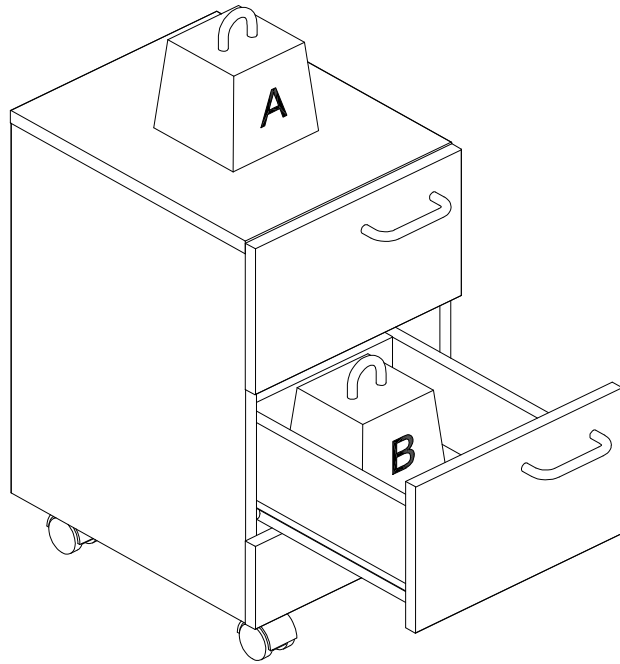





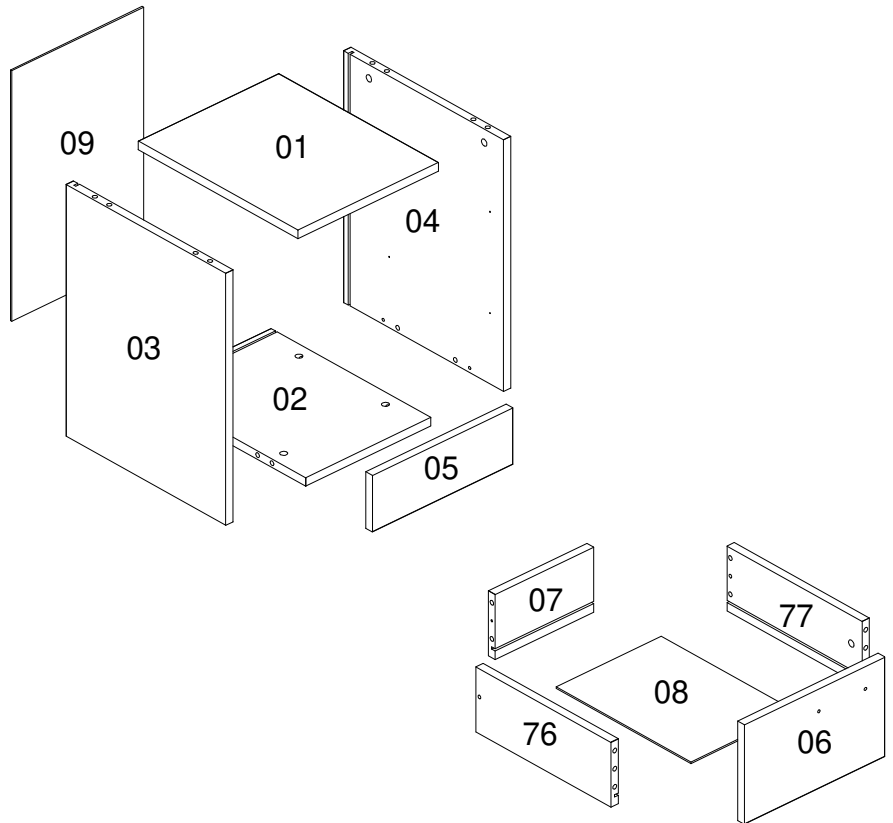



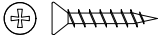

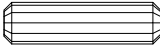

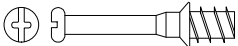

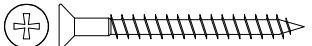
Nº	Measures Inches	Medidas cm	Qty./Qtd.
01	11 3/8 x 14 x 5/8	29 x 35,5 x 1,5	1
02	10 1/8 x 14 x 5/8	25,8 x 35,5 x 1,5	1
03	17 1/2 x 14 x 5/8	44,5 x 35,5 x 1,5	1
04	17 1/2 x 14 x 5/8	44,5 x 35,5 x 1,5	1
05	11 3/8 x 3 7/8 x 5/8	29 x 10 x 1,5	1
06	11 3/8 x 6 7/8 x 5/8	29 x 17,6 x 1,5	2
07	8 x 4 1/2 x 5/8	20,3 x 11,5 x 1,5	2
08	8 1/2 x 11 3/4 x 1/8	21,7 x 29,9 x 0,3	2
09	17 1/2 x 10 3/4 x 1/8	44,3 x 27,2 x 0,3	1
76	11 3/4 x 4 1/2 x 5/8	30 x 11,5 x 1,5	2
77	11 3/4 x 4 1/2 x 5/8	30 x 11,5 x 1,5	2

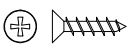
PARTS IDENTIFICATION
IDENTIFICAÇÃO DAS PEÇAS / IDENTIFICACIÓN DE LAS PIEZAS

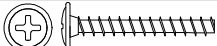

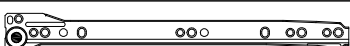
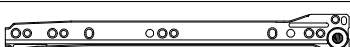
IDENTIFICATION OF ACCESSORIES IDENTIFICAÇÃO DOS ACESSÓRIOS/ IDENTIFICACIÓN DE ACCESORIOS

A1		Glue / Cola / Pegamento	13 g	1
A8		Flat head screw / Parafuso chato / Tornillo de cabeza plana	3,5x20 mm	4
B5		Metalic angle plates / Cantoneira de metal / Suporte de metal	46 mm	2
E		Wooden dowel / Cavilha / Taquete	8x30 mm	24
H6A		Caster / Rodízio 40 / Rueda	-	4
J		Simple minifix screw / Haste minifix simples / Tornillo minifix simple	-	12
L		Drum lock / Tambor minifix / Tambor minifix	12 mm	12
M		Bore patch adhesive / Tapa furo adesivo / Tapones adhesivo	-	4
O		Flat head screw / Parafuso chato / Tornillo de cabeza plana	4,5x45 mm	4
o1		Triangular support / Suporte triangular / Soporte triangular	-	4
P5		Flat head screw / Parafuso chato especial / Tornillo de cabeza plana	3,5x14 mm	16
S		Pan head screw / Parafuso panela / Tornillo de pan	3,5x14 mm	24
T		Flanged head screw / Parafuso flangeado / Tornillo de cabeza flangeada	3,5x25 mm	4
W7		Handle / Puxador Goleira / Tirador	96 mm	2
XA		Metallic slide the left field / Corrediça lateral esquerda / Corredera lateral izquierda	300 mm	2
XB		Metallic slide the right field / Corrediça lateral direita / Corredera lateral derecha	300 mm	2
XC		Drawer slide left / Corrediça gaveta esquerda / Corredera izquierda cajón	300 mm	2
XD		Drawer slide right / Corrediça gaveta direita / Corredera derecha cajón	300 mm	2



PRE-ASSEMBLE
PRÉ-MONTAGEM / PRE ARMADO

01

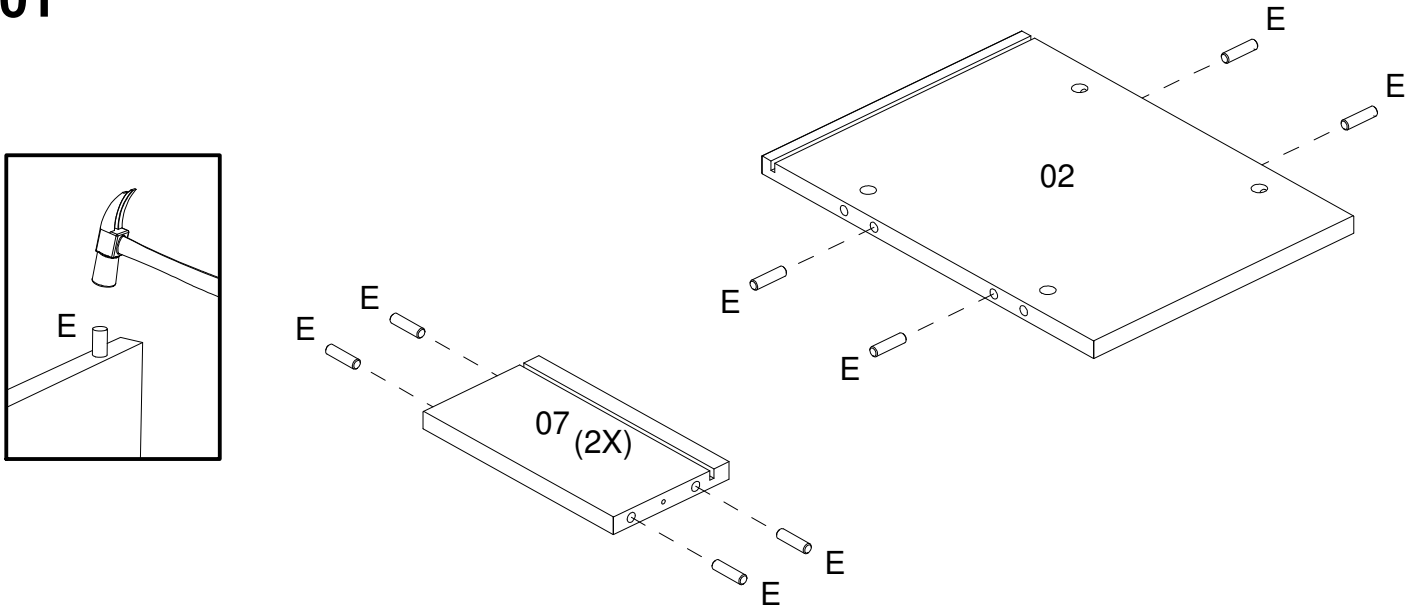

02

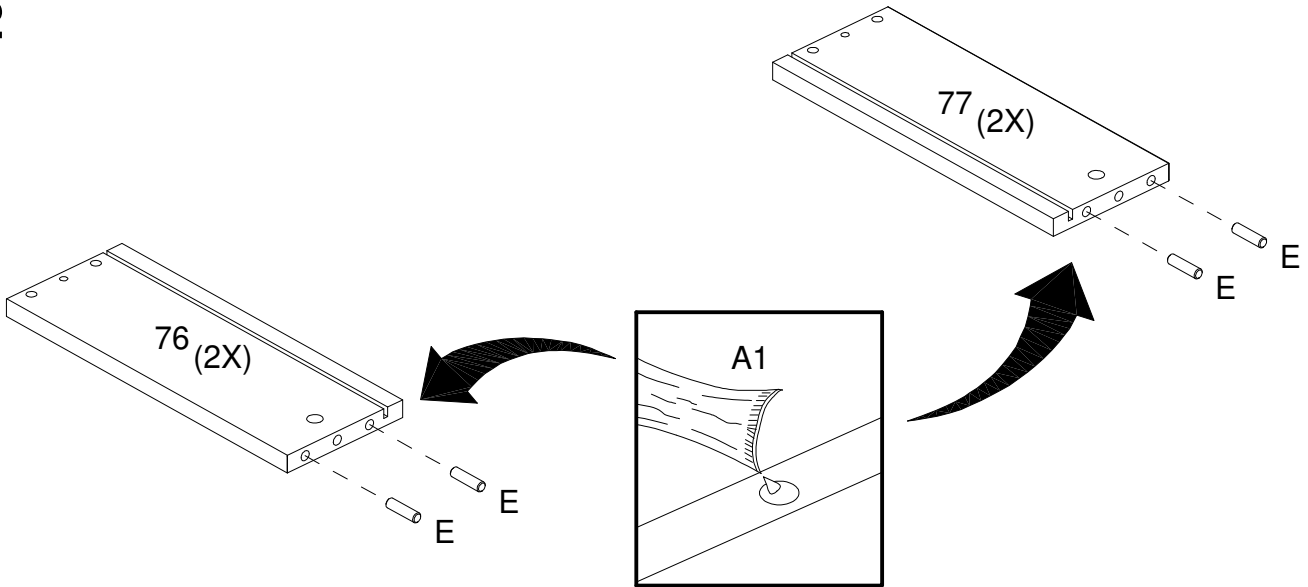

03

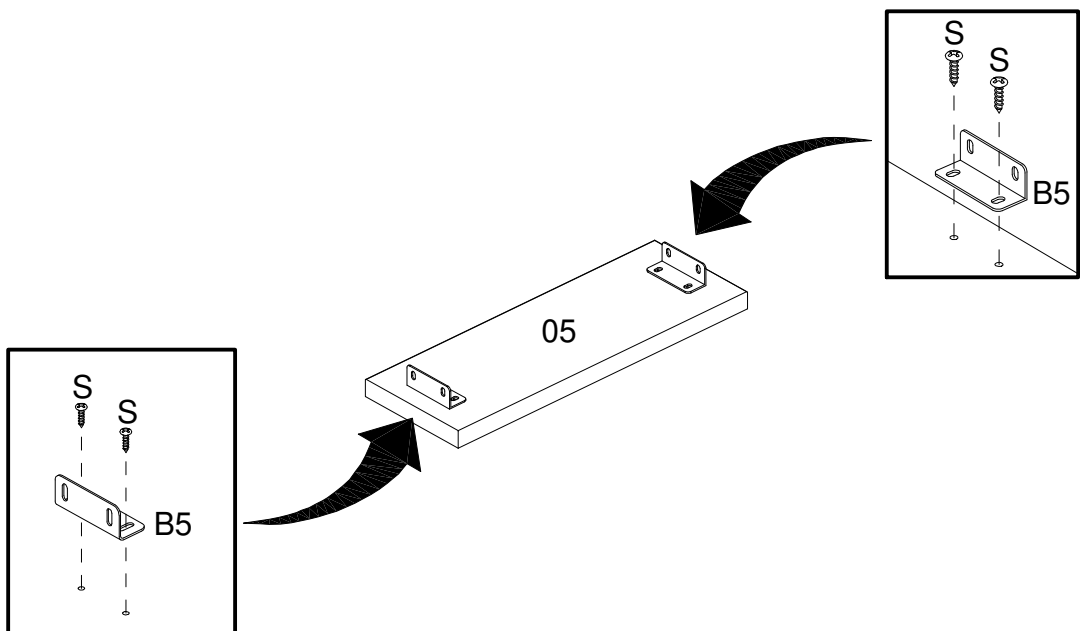

04

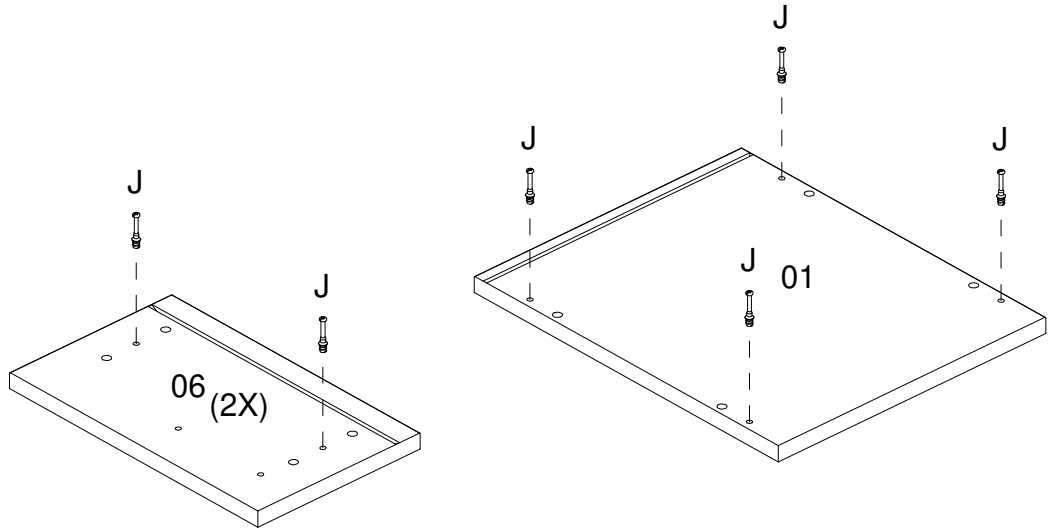
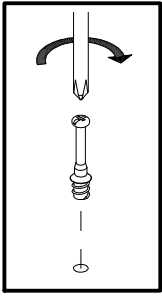

05

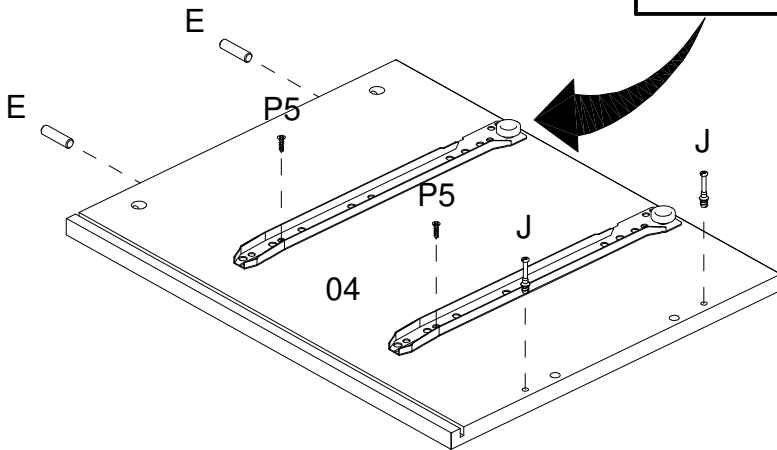
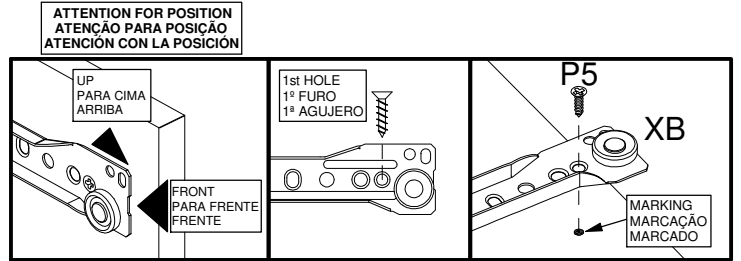

06

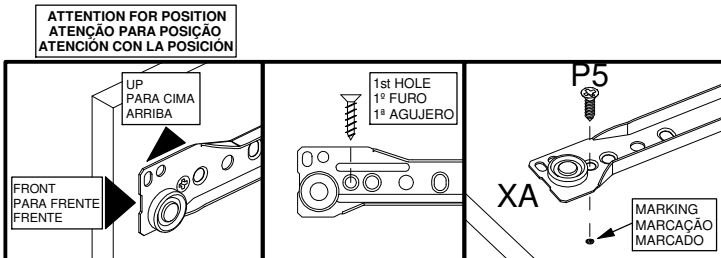
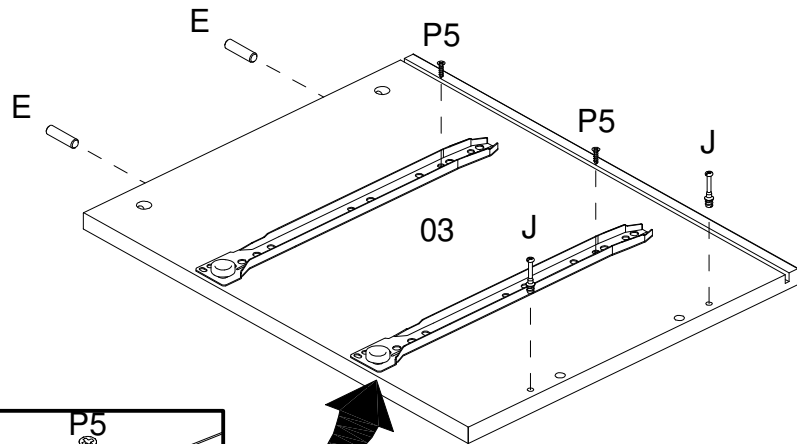

**ASSEMBLY
MONTAGEM / ARMADO**

07

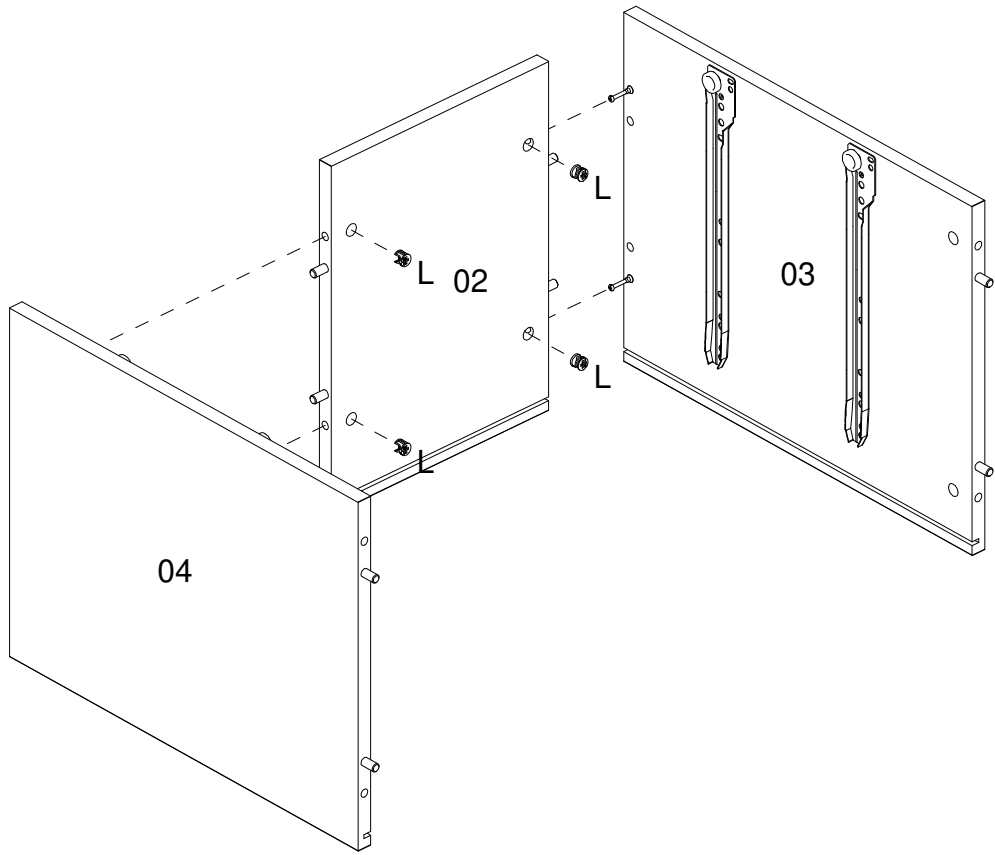
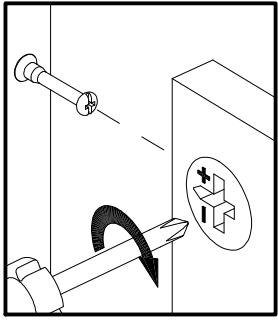

08

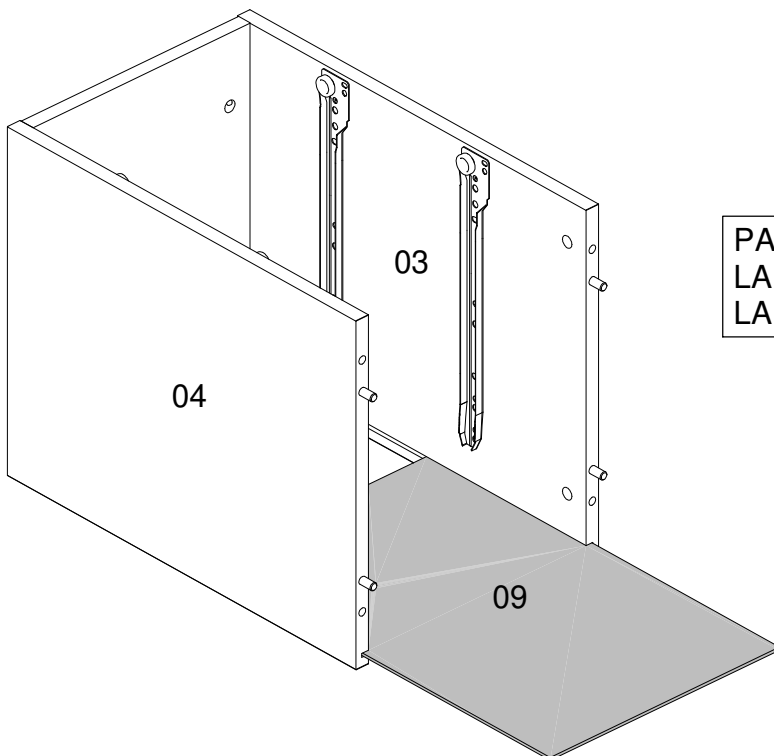
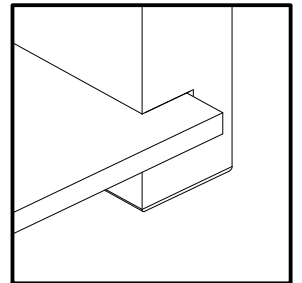

**PAINTED SIDE DOWN
LADO PINTADO PARA BAIXO
LADO PINTADO ABAJO**

09

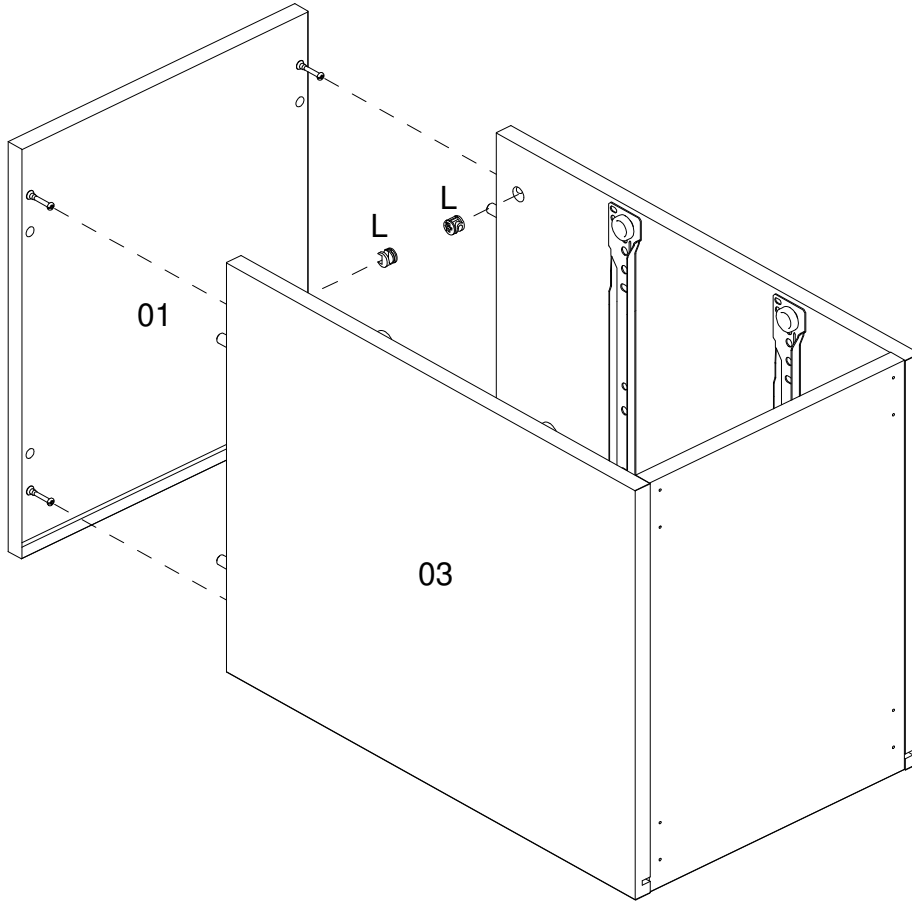

10

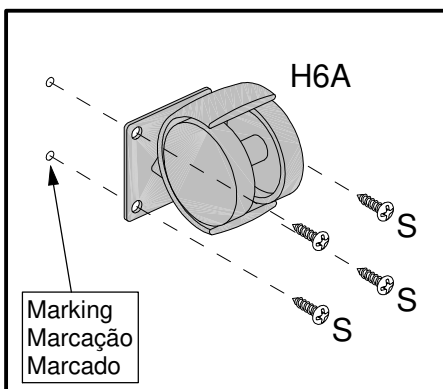
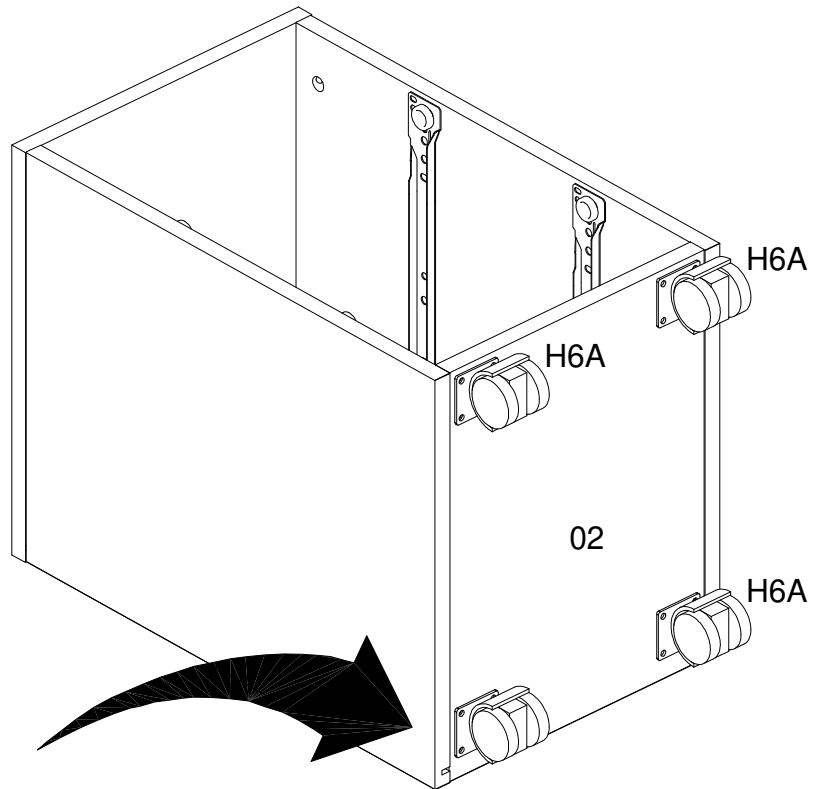

11

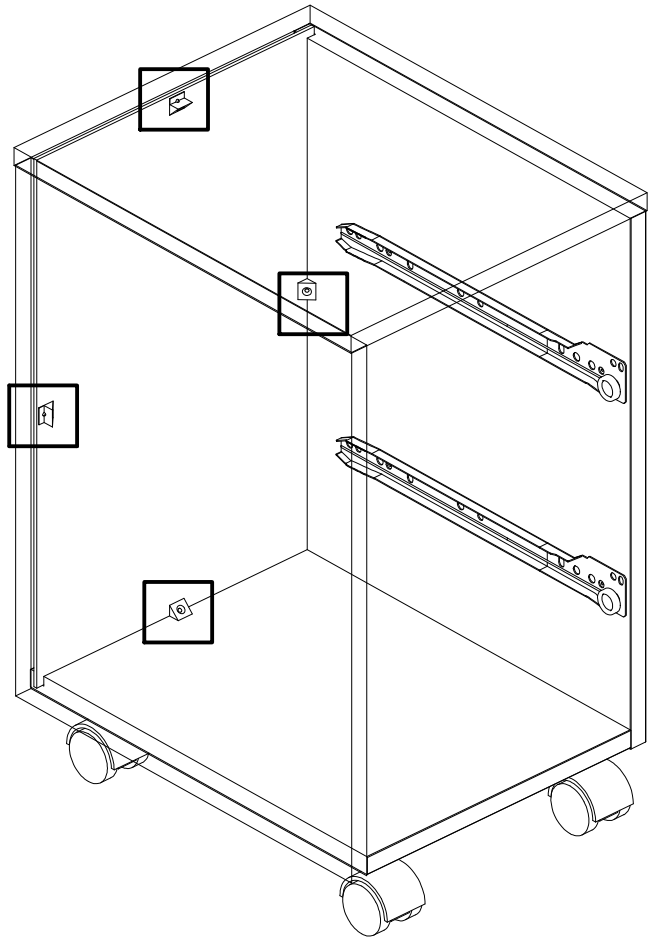
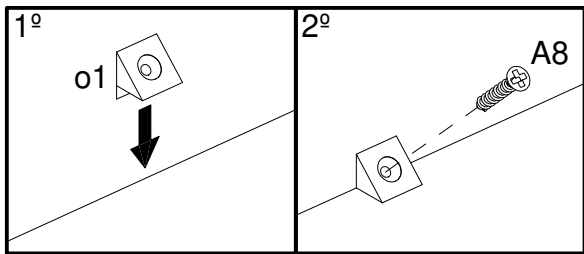

12

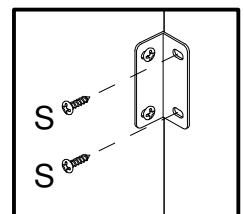
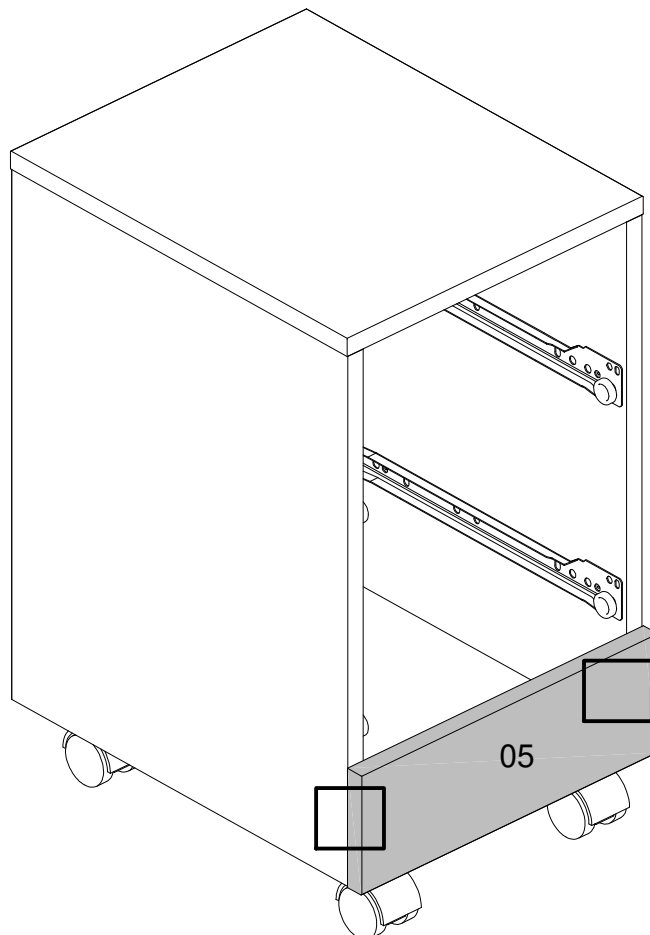

13

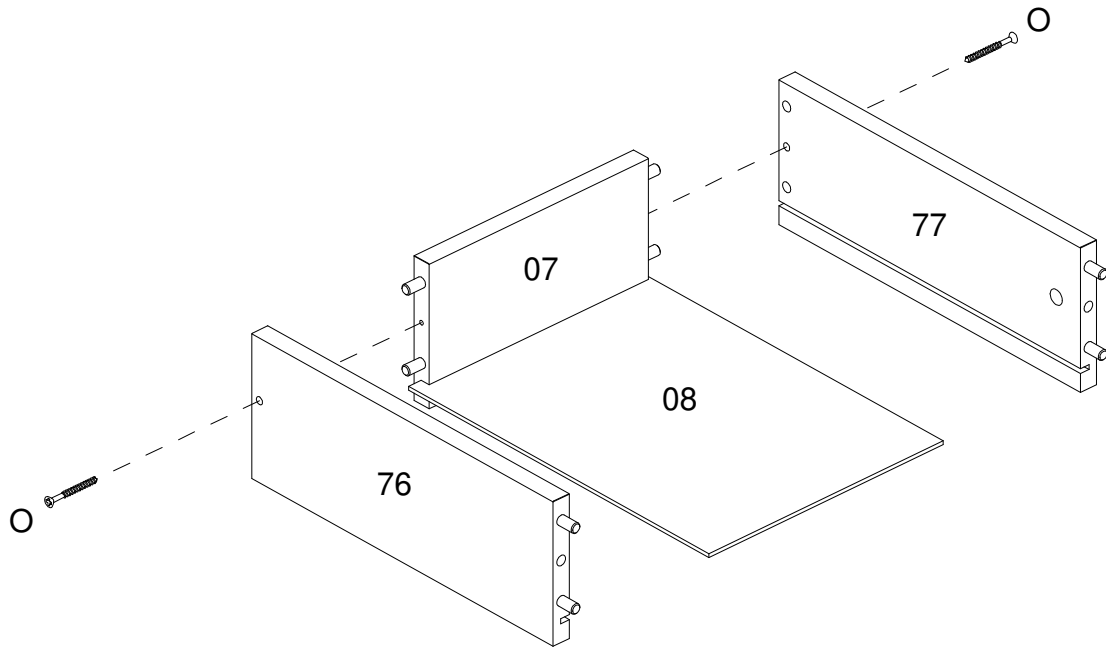

14

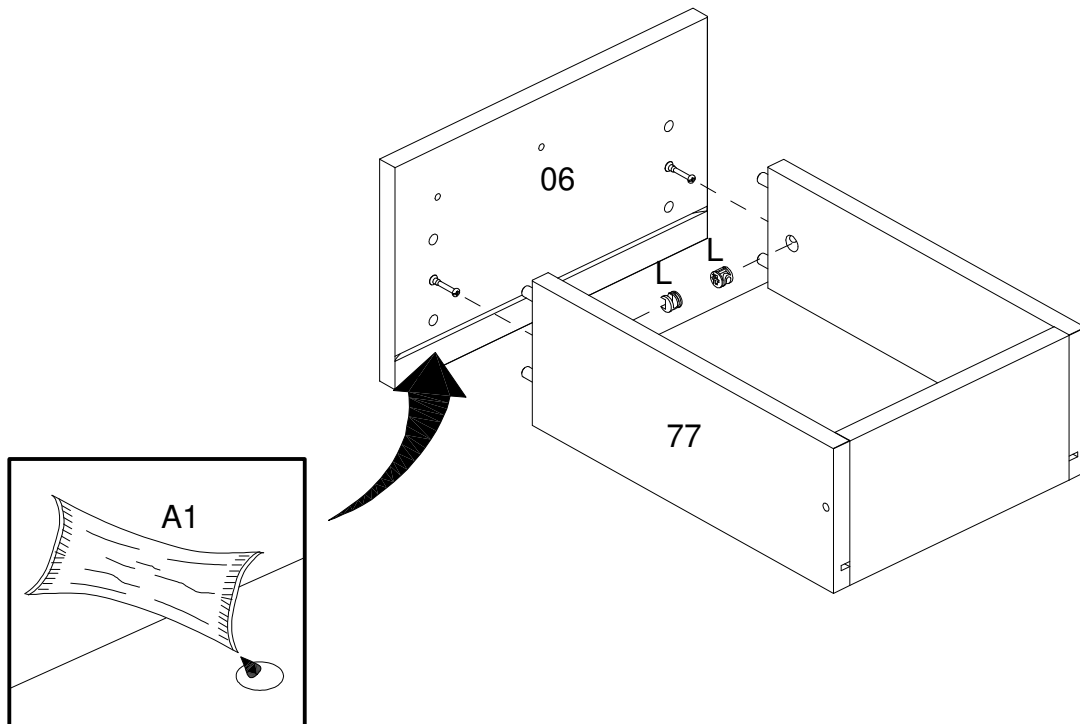

15

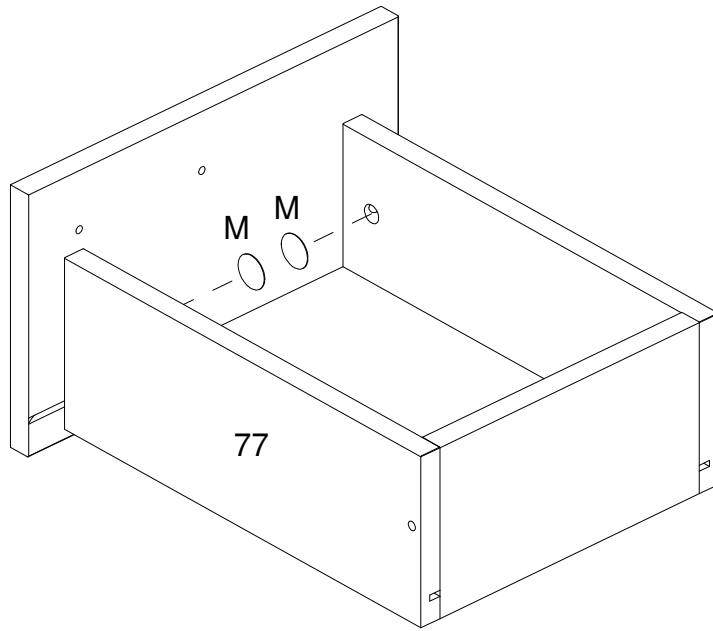

16

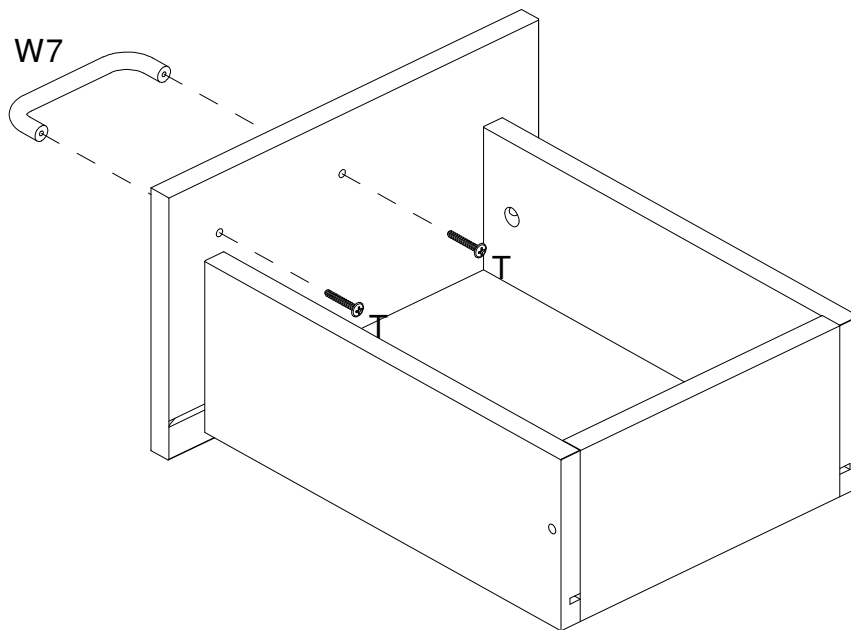

17

THE UNDERSIDE OF THE DRAWER
LADO INFERIOR DA GAVETA
PARTE INFERIOR DEL CAJÓN

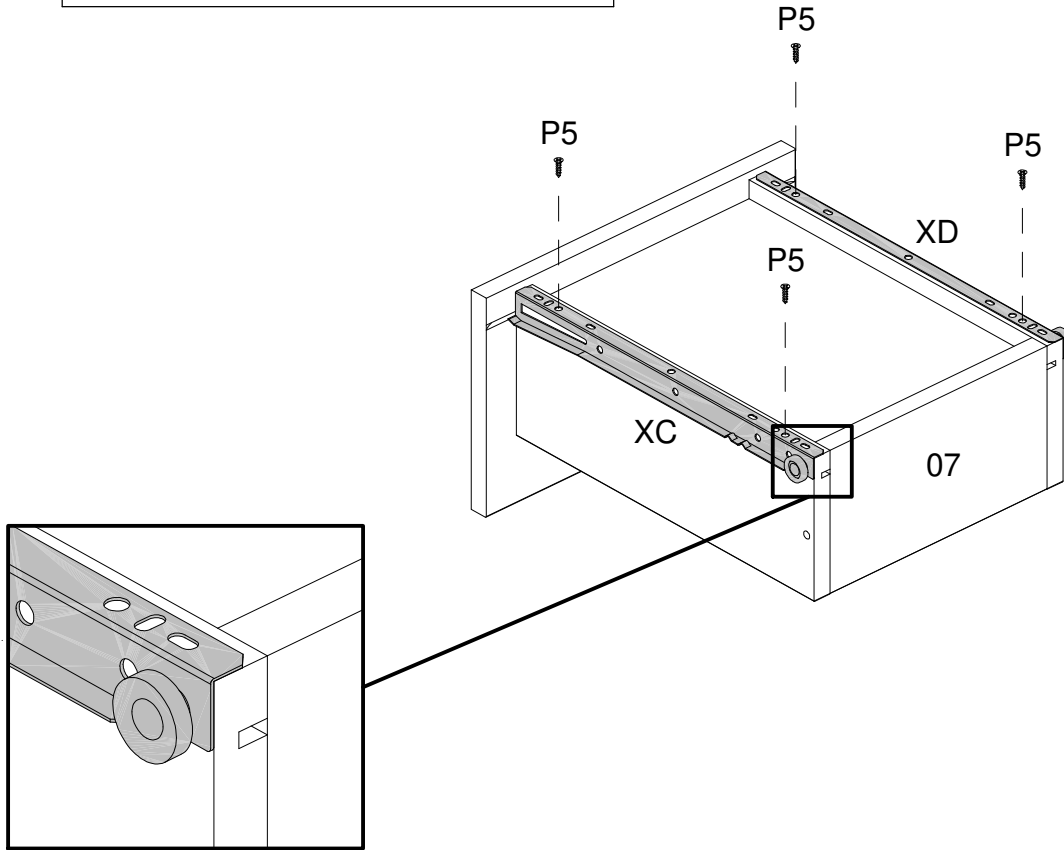

18

