

## 2085 - CAMARIM BLUSH

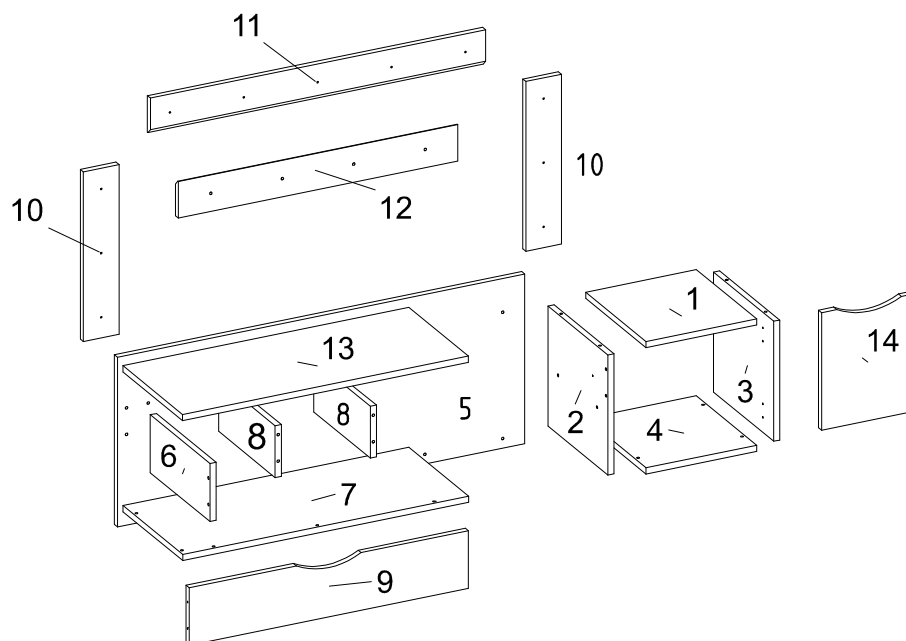

LISTA DE PEÇAS / Pieces List / Lista de Piezas

SEQ.	REF.	DESCRIÇÃO	DESCRIPTION	DESCRIPCIÓN	MAT.PRIMA	COMP.	LARG.	ESP.	QTD.
1	15775	TAMPO	Top	Arriba	MDP	273	298	15	1
2	15776	DIVISORIA	Divisoria	Divisoria	MDP	290	296	15	1
3	15777	LATERAL DIREITA	Right Lateral	Lateral derecho	MDP	290	296	15	1
4	15778	BASE	Base	Base	MDP	273	298	15	1
5	15779	PAINEL	Panel	Panel	MDP	1005	410	15	1
6	15780	LATERAL ESQUERDA	Left side	Lado izquierdo	MDP	295	140	15	1
7	15781	PRATELEIRA	Shelf	Estante	MDP	705	295	15	1
8	15782	DIVISÓRIA DO NICHU	Niche partition	Partición de nicho	MDP	279	125	15	2
9	15783	VISTA FRONTAL	Front view	Vista frontal	MDP	689	139	15	1
10	15784	TRAVESSA LATERAL	Side Rail	Side Rail	MDP	410	88	15	2
11	15785	MACHO FEMEA COM BORDA	Man femea	Macho femeá	MDP	827	88	15	1
12	15786	MACHO FEMEA SEM BORDA	Man femea	Macho femeá	MDP	689	88	15	1
13	15787	PORTA BASCULANTE	Swing Door	Puerta oscilante	MDP	705	295	15	1
14	15788	PORTA	Door	Puerta	MDP	284	235	15	1

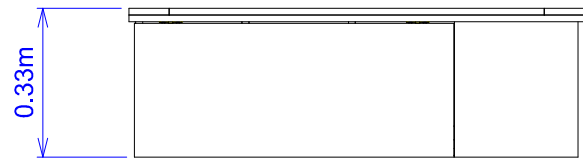
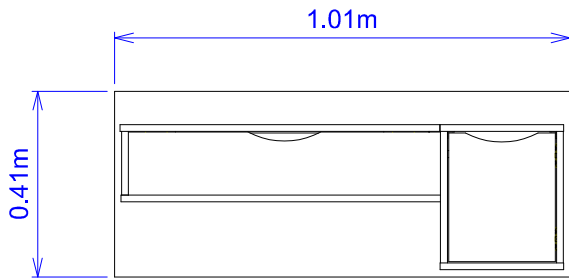

Dimensão do Produto: (L X A X P) - 1.01 x 0.41 x 0.33

INSTRUÇÃO MONTAGEM PRODUTO  
Instructions to Assembly / Instrucciones de montaje

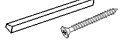

Separe as peças e acessórios de maneira organizada  
Separate parts and accessories in way organized  
Separe las piezas y accesorios de manera organizada



Forrar o chão com o papelão das embalagens.  
Cover the floor with the cardboard  
Cubra el suelo con la embalaje de cartón



É necessário 01 pessoa para montar o produto  
It is necessary one person to assembly  
Es necesario una persona para ensamblar

O produto deve ser a montado por um profissional qualificado  
The product must be assembly by a professional  
El producto debe ser ensamblado por un profesional calificado

Ferramentas necessárias  
(não fornecidas)  
Not include tools / No herramientas



CUIDADO PARA CONSERVAÇÃO E LIMPEZA DO MÓVEL  
Care to conservation and clean / Cuidados de limpieza



O peso máximo de carga informado refere-se a objetos distribuído de maneira uniforme sobre toda área de contato da peça  
Set maximum weight load refers to objects distributed uniformly over the entire contact area of the workpiece.  
Conjunto de carga máxima de peso se refiere a objetos distribuidos uniformemente sobre toda el área de contacto de la pieza de trabajo.



Não molhar o móvel e não expor em lugar úmido  
Do not wet the mobile and do not expose in a wet place  
No moje el producto y no exponer en un lugar húmedo



Não expor o móvel próximo de fontes de calor.  
Do not expose the mobile near heat sources  
no exponga cercano de fuentes de calor



Não usar produtos abrasivos.  
Do not use abrasive products.  
No utilice productos abrasivos.



Limpe com flanela limpa e seca.  
Clean with dry cloth  
Limpieza con un paño limpio y seco

LISTA DE ACESSÓRIOS E FERRAGEM / ACCESSORIES AND HARDWARE / ACCESORIOS Y EQUIPOS



A - Parafuso 4,5x45 (25)  
screw / tornillo



B- Parafuso 3,5x25 (11x)  
screw / tornillo



C- Parafuso 3,5x12 (16x)  
screw / tornillo

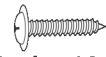

D - Parafuso 4,0x12 (16x)  
screw / tornillo



E - Dobradiça (4x)  
hinge / bisagra



F- Cavilha 6x30 (8x)  
Peg / cerrojo



G- Cantoneira (7x)  
Corner / esquina



H - Espelho (1x)  
Mirror/espejo



I- Pistão a gas (1x)  
Pistón gas



J- Bucha parede (4x)  
wall bushing /  
casquillo de la pared



K- Parafuso 4.5 x 60 (4x)  
screw / tornillo



L- Parafuso 4,0x16 (1x)  
Screw / tornillo



M- Suporte prateleira (1x)  
Shelf bracket/suporte de estante



N - PARAFUSO UNIÃO (4)  
Union screw / Tornillo de unión



O - Gota de silicone (3x)  
Silicone drop/Gota de silicona

01° PASSO	Fixar peças 2 e 3 nas peças 1 e 4	02° PASSO	Fixar peças 1 e 4 na peça 5
01° STEP	Attach parts 2 and 3 to parts 1 and 4	02° STEP	Attach parts 1 and 4 to part 5
01° PASO	Adjunte las partes 2 y 3 a las partes 1 y 4	02° PASO	Adjunte las partes 1 y 4 a la parte 5
A		A	
C		-	
F		-	
G		-	
-		-	
03° PASSO	Fixar peças 6 e 8 na peça 5	04° PASSO	Fixar peças 7 e 9 nas peças 2 e 6
03° STEP	Attach parts 6 and 8 to part 5	04° STEP	Attach parts 7 and 9 to parts 2 and 6
03° PASO	Adjunte las partes 6 y 8 a la parte 5	04° PASO	Adjunte las partes 7 y 9 a las partes 2 y 6
A		A	
F		C	
-		G	
-		L	
-		M	
05° PASSO	Fixar peça 13 na peça 5 e fixar peça 14 na peça 3	06° PASSO	Fixar peças 10 , 11 na peça 5, encaixar peça 11 sobre a peça 12
05° STEP	Attach part 13 to part 5 and attach part 14 to part 3	06° STEP	Attach parts 10, 11 to part 5, Fit Part 11 on the part 12
05° PASO	Adjunte la parte 13 a la parte 5 y adjunte la parte 14 a la parte 3	06° PASO	Adjunte las partes 10, 11 la parte 5, Ajuste Parte 11 en la parte 12
D		B	<p>Fixar peça 12 na parede Fix part 12 on the wall Fije la parte 12 en la pared</p>
E		J	
-		K	
I		-	
N		-	

